

ARIZONA STATE TRANSPORTATION BOARD

Katie Hobbs, Governor

Ted Maxwell, Chairman
Jenny Howard, Vice Chair
Sam Elters, Member
Jamescita Peshlakai, Member
Bruce Bracker, Member
John Giles, Member
Doug Coleman, Member
Vacant, Member

Welcome to a meeting of the Arizona State Transportation Board. The Transportation Board consists of eight private citizen members appointed by the Governor, representing specific transportation districts. Board members are appointed for terms of six years each, with terms expiring on the third Monday in January of the appropriate year.

BOARD AUTHORITY

Although the administration of the Department of Transportation is the responsibility of the director, the Transportation Board has been granted certain policy powers in addition to serving in an advisory capacity to the director. In the area of highways the Transportation Board is responsible for establishing a system of state routes. It determines which routes are accepted into the state system and which state routes are to be improved. The Board has final authority on establishing the opening, relocating, altering, vacating or abandoning any portion of a state route or a state highway. The Transportation Board awards construction contracts and monitors the status of construction projects. With respect to aeronautics the Transportation Board distributes monies appropriated to the Aeronautics Division from the State Aviation Fund for planning, design, development, land acquisition, construction and improvement of publicly-owned airport facilities. The Board also approves airport construction. The Transportation Board has the exclusive authority to issue revenue bonds for financing needed transportation improvements throughout the state. As part of the planning process the Board determines priority planning with respect to transportation facilities and annually adopts the five year construction program.

PUBLIC INPUT

Members of the public may appear before the Transportation Board to be heard on any transportation-related issue. Persons wishing to protest any action taken or contemplated by the Board may appear before this open forum. The Board welcomes citizen involvement, although because of Arizona's open meeting laws, no actions may be taken on items which do not appear on the formal agenda. This does not, however, preclude discussion of other issues.

MEETINGS

The Transportation Board typically meets on the third Friday of each month. Meetings are held in locations throughout the state. **Due to potential health risks at large public gatherings, the Transportation Board asks that people attending Board meetings in person take safety precautions they feel appropriate to protect themselves and others. In addition, for the time being the Transportation Board will conduct concurrent telephonic/WebEx virtual meetings.** In addition to the regular business meetings held each month, the Board may conduct at least one public hearings each year to receive input regarding the proposed five-year construction program. Meeting dates are established for the following year at the December organization meeting of the Board.

BOARD MEETING PROCEDURE

Board members receive the agenda and all backup information one week before the meeting is held. They have studied each item on the agenda and have consulted with Department of Transportation staff when necessary. If no additional facts are presented at the meeting, they often act on matters, particularly routine ones, without further discussion. In order to streamline the meetings the Board has adopted the "consent agenda" format, allowing agenda items to be voted on en masse unless discussion is requested by one of the board members or Department of Transportation staff members.

BOARD CONTACT

Transportation Board members encourage citizens to contact them regarding transportation-related issues. Board members may be contacted through the Arizona Department of Transportation, 206 South 17th Avenue, Phoenix, Arizona 85007, Telephone (602) 712-7550.

NOTICE OF BOARD MEETING OF THE STATE TRANSPORTATION BOARD

Pursuant to A.R.S. Sec. 38-431.02, notice is hereby given to the members of the State Transportation Board and to the general public that the State Transportation Board will hold a board meeting open to the public on Friday, June 19, 2026, at 9:00 a.m. The Board may vote to go into Executive Session to discuss certain matters, which will not be open to the public. Members of the Transportation Board may attend in person, or by telephone or video conference. The Board may modify the agenda order, if necessary.

EXECUTIVE SESSION OF THE STATE TRANSPORTATION BOARD

Pursuant to A.R.S. 38-431.02, notice is hereby given to the members of the Arizona State Transportation Board and to the general public that the Board may meet in Executive Session for discussion or consultation of legal advice with legal counsel at its meeting on Friday, June 19, 2026, relating to any items on the agenda. Pursuant to A.R.S. 38-431.03(A), the Board may, at its discretion, recess and reconvene the Executive Session as needed, relating to any items on the agenda.

CIVIL RIGHTS

Pursuant to Title VI of the Civil Rights Act of 1964, and the Americans with Disabilities Act (ADA), ADOT does not discriminate on the basis of race, color, national origin, age, sex or disability. Persons that require a reasonable accommodation based on language or disability should contact the Civil Rights Office at (602) 712-8946 or email CivilRightsOffice@azdot.gov. Requests should be made as early as possible to ensure the state has an opportunity to address the accommodation.

De acuerdo con el título VI de la Ley de Derechos Civiles de 1964 y la Ley de Estadounidenses con Discapacidades (ADA por sus siglas en Inglés), el Departamento de Transporte de Arizona (ADOT por sus siglas en Inglés) no discrimina por raza, color, nacionalidad, edad, género o discapacidad. Personas que requieren asistencia (dentro de lo razonable) ya sea por idioma o por discapacidad deben ponerse en contacto con 602.712.8946. Las solicitudes deben hacerse lo más pronto posible para asegurar que el equipo encargado del proyecto tenga la oportunidad de hacer los arreglos necesarios.

AGENDA

A copy of the agenda for this meeting will be available at the office of the Transportation Board at 206 S. 17th Avenue, Phoenix, Arizona at least 24 hours in advance of the meeting.

ORDER DEFERRAL AND ACCELERATIONS OF AGENDA ITEMS, VOTE WITHOUT DISCUSSION

In the interest of efficiency and economy of time, the Arizona Transportation Board, having already had the opportunity to become conversant with items on its agenda, will likely defer action in relation to certain items until after agenda items requiring discussion have been considered and voted upon by its members. After all such items to discuss have been acted upon, the items remaining on the Board's agenda will be expedited and action may be taken on deferred agenda items without discussion. It will be a decision of the Board itself as to which items will require discussion and which may be deferred for expedited action without discussion.

The Chairman will poll the members of the Board at the commencement of the meeting with regard to which items require discussion. Any agenda item identified by any Board member as one requiring discussion will be accelerated ahead of those items not identified as requiring discussion. All such accelerated agenda items will be individually considered and acted upon ahead of all other agenda items. With respect to all agenda items not accelerated. i.e., those items upon which action has been deferred until later in the meeting, the Chairman will entertain a single motion and a single second to that motion and will call for a single vote of the members without any discussion of any agenda items so grouped together and so singly acted upon. Accordingly, in the event any person desires to have the Board discuss any particular agenda item, such person should contact one of the Board members before the meeting or ADOT Staff, at 206 South 17th Avenue, Room 133, Phoenix, Arizona 85007, or by phone (602) 712-7550. Please be prepared to identify the specific agenda item or items of interest.

Dated this 12th day of June, 2026

State Highway System with Railroads & Airports

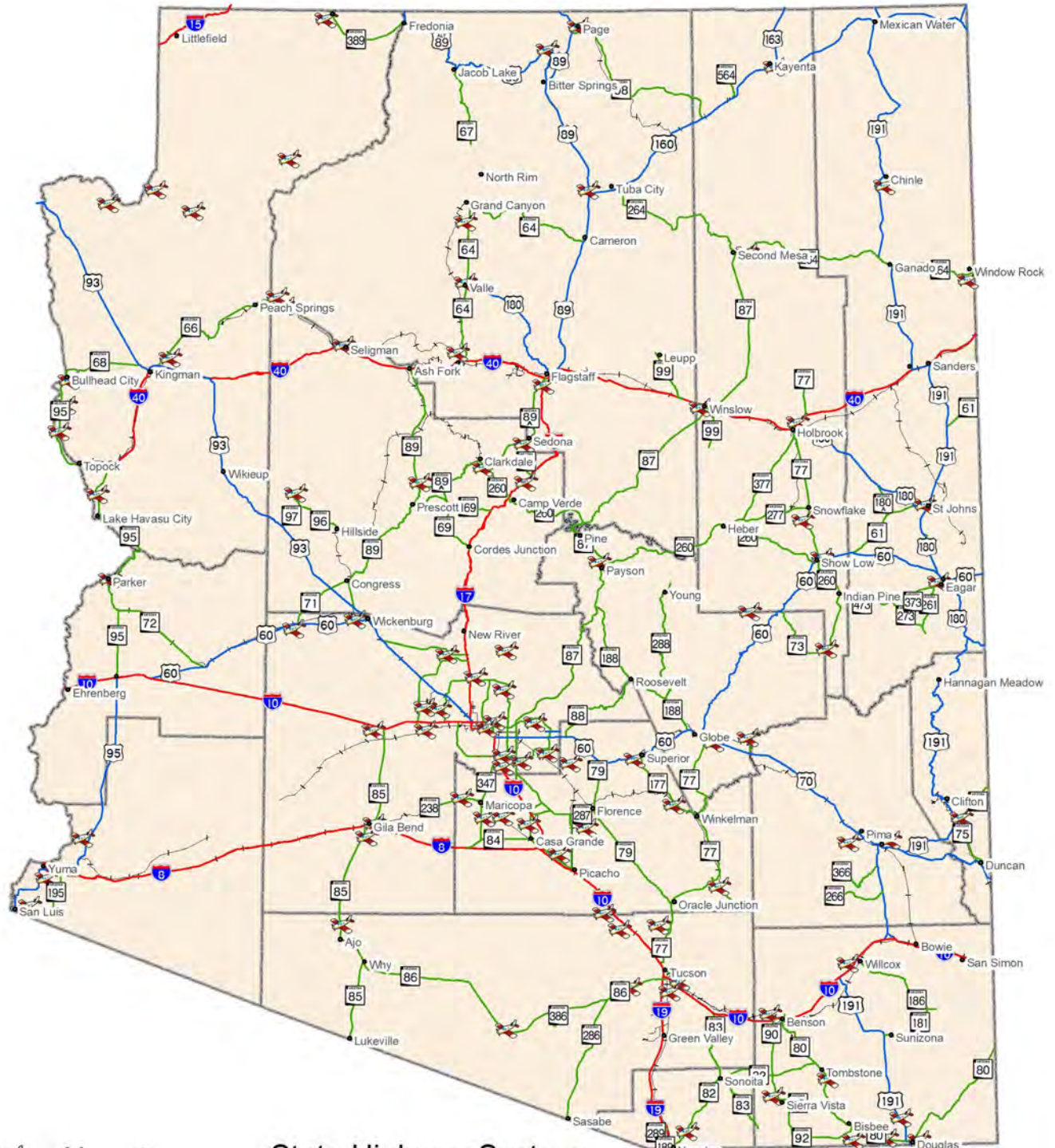

- | | | | |
|---|----------------|---|-------------|
|  | Airport |  | Interstate |
|  | Cities & Towns |  | US Highway |
|  | Railroad |  | State Route |
|  | County Line | | |

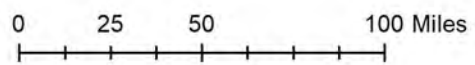

Note:
The State of Arizona makes no claims concerning the accuracy of this map nor assumes any liability resulting from the use of the information herein.

Prepared by:
Arizona Department of Transportation
Multimodal Planning Division
Geospatial Analysis Section
mpdgis@azdot.gov 2023005 November 2023

ARIZONA STATE TRANSPORTATION BOARD

**STATE TRANSPORTATION BOARD
IN PERSON WITH OPTIONAL TELEPHONIC/WEBEX ATTENDANCE
BOARD MEETING
Santa Cruz County Board of Supervisors
2150 N. Congress Drive
Nogales, AZ 85621
9:00 a.m., Friday, June 19, 2026**

Telephonic Pursuant to A.R.S. Sec. 38-431.02, notice is hereby given to the members of the State Transportation Board and to the general public that the State Transportation Board will hold a board meeting open to the public on Friday, June 19th, 2026, at 9:00 a.m. The Board may vote to go into Executive Session, which will not be open to the public. Members of the Transportation Board may attend in-person at or by telephone or video conference call. The Board may modify the agenda order, if necessary.

Public Participation Members of the public who want to observe or participate in the Transportation Board meeting can either attend in person or access the meeting by using the WebEx meeting link at www.aztransportationboard.gov. Join the meeting as a participant and follow the instruction to use your telephone to enable audio. For members of the public attending in person, physical access to the meeting place begins at 8:00 a.m.

EXECUTIVE SESSION OF THE STATE TRANSPORTATION BOARD

Pursuant to A.R.S. 38-431.03 (A)(3), notice is hereby given to the members of the Arizona State Transportation Board and to the general public that the Board may meet in Executive Session for discussion or consultation for legal advice with legal counsel at its meeting on Friday June 19, 2026. The Board may, at its discretion, recess and reconvene the Executive Session as needed, relating to any items on the agenda.

PLEDGE

The Pledge of Allegiance

ROLL CALL

Roll call by Board Secretary

OPENING REMARKS

Opening remarks by Chairman Maxwell

TITLE VI OF THE CIVIL RIGHTS ACT OF 1964, as amended.

Reminder to fill out survey cards presentation

<https://docs.google.com/forms/d/e/1FAIpQLSdr7eC3VJShEFhDFijBRREvZGFhxJWP68MpJrUYlhRXcZVqVg/viewform>

CALL TO THE AUDIENCE (information only)

VIRTUAL:

An opportunity for citizens to discuss items of interest with the Board . To address the Board please fill out a Request for Public Input Form and email the form to boardinfo@azdot.gov. The form is located on the Transportation Board’s website <https://aztransportationboard.gov/index.asp>. Request for Public Input Forms will be taken until 8:00 AM the morning of the Board Meeting. Since this is a telephonic/WebEx conference meeting everyone will be muted when they call into the meeting. When your name is called to provide your comments, you will indicate your presence by virtually raising your hand using your phone keypad or through the WebEx application.

To raise your hand over the phone:

If you have joined us using your telephone, raise your hand by pressing *3 on your phone keypad. You will be unmuted by the meeting moderator and asked to make your comments. When you have finished speaking or when your time is up, please lower your hand by pressing *3 on your phone keypad.

To raise your hand using the WebEx computer or internet browser application:

If you have joined us using the WebEx computer or internet browser application, open your participant panel located on the menu on the bottom left of your screen. When the participant panel opens, click on the hand icon on the right side of your name on the participant panel. You will be unmuted by the meeting moderator and asked to make your comment. When you have finished making your comment, the moderator will mute your line and we ask that you please lower your hand by clicking on the hand icon again.

To raise your hand using the WebEx iPhone or Android application:

If you have joined us using the WebEx iPhone or Android application, select the three dot menu icon on the bottom of the screen. When it opens, select “Raise Hand” at the top of the menu screen. You will be unmuted by the meeting moderator and asked to make your comment. When you have finished speaking, the moderator will mute your line and we ask that you please lower your hand by clicking on the hand icon again.

IN PERSON:

An opportunity for members of the public to discuss items of interest with the Board. Please fill out a Request for Public Input Form and turn in to the Secretary if you wish to address the Board.

A three minute time limit will be imposed.

BOARD MEETING**ITEM 1: Director's Report**

The Director will provide a report on current issues and events affecting ADOT.

(For information and discussion only — Jennifer Toth, Director)

A) Overview of successes and current activities**B) Legislative Report****C) Last Minute Items to Report**

(For information only. The Transportation Board is not allowed to propose, discuss, deliberate or take action on any matter under "Last Minute Items to Report," unless the specific matter is properly noticed for action.)

ITEM 2: District Report— No District Report

Staff will provide an update and overview of issues of regional significance, including an update on current and upcoming construction projects, district operations, maintenance activities and any regional transportation studies.

(For information and discussion only —)

***ITEM 3: Consent Agenda**

Page 9

Consideration by the Board of items included in the Consent Agenda. Any member of the Board may ask that any item on the Consent Agenda be pulled for individual discussion and disposition. (For information and possible action)

Items on the Consent Agenda generally consist of the following:

- Minutes of previous Board Meeting
- Minutes of Special Board Meeting
- Minutes of Study Sessions
- Right-of-Way Resolutions
- Construction Contracts that have no bidder protest or State Engineer inquiry and meet the following criteria:
 - Low bidder is no more than 15% under state estimate
 - Low bidder is no more than 10% over state estimate
- Programming changes for items that are a part of the approved scope of the project if they do not exceed 15% or \$200,000, whichever is lesser.

ITEM 4: Financial Report

Staff will provide an update on financing issues and summaries on the items listed below: (For information and discussion only — Elise Maza, Acting Deputy CFO)

- Revenue Collections for Highway User Revenues
- Maricopa Transportation Excise Tax Revenues
- Aviation Revenues
- Interest Earnings
- HELP Fund status
- Federal-Aid Highway Program
- HURF and RARF Bonding
- GAN issuances
- Board Funding Obligations
- Contingency Report

***ITEM 5: Final Approval of the FY 2027—2031 ADOT Five-Year Transportation Facilities Construction Program.**

Staff will present the FY 2027—2031 ADOT Five-Year Transportation Facilities Construction Program for Board review, discussion and approval of the program. To review the online tentative program use the following link:

[2027-2031 Tentative ADOT Five-Year Program](#)

(For discussion and possible action — Iqbal Hossain, Deputy Division Director, Multimodal Planning Division)

ITEM 6: Multimodal Planning Division Report

Pursuant to A.R.S. 28-506, staff will present an update on the current planning activities, to include the following:

- A) Tribal Transportation Update
- C) Last Minute items

(For information and discussion only — Iqbal Hossain, Deputy Division Director, Multimodal Planning Division)

ITEM 7: AZ State Match Advantage for Rural Transportation (AZ SMART) Fund Program

Page 74

Staff will present AZ SMART fund program applications from various eligible applicants for the Transportation Board's consideration and approval. Representatives from the applicants may be available for questions.

- A) June 2026 AZ SMART Fund Report

(For information and discussion only — Iqbal Hossain, Deputy Division Director, Multimodal Planning Division)

***ITEM 8: Priority Planning Advisory Committee (PPAC)**

Page 75

Staff will present recommended PPAC actions to the Board including consideration of changes to the FY2026 - 2030 Statewide Transportation Facilities Construction Program.

(For discussion and possible action — Iqbal Hossain, Deputy Division Director, Multimodal Planning Division)

ITEM 9: State Engineer's Report

Page 94

Staff will present a report showing the status of highway projects under construction, including total number and dollar value. Provide an overview of Construction, Transportation and Operations Program impact, due to the public health concerns.

(For information and discussion only — Audra Merrick, State Engineer/ Deputy Director)

*ITEMS that may require Board Action

***ITEM 10: Construction Contracts**

Staff will present recommended construction project awards that are not on the Consent Agenda.

(For discussion and possible action — Audra Merrick, State Engineer/Deputy Director)

ITEM 11: Suggestions

Board Members will have the opportunity to suggest items they would like to have placed on future Board Meeting agendas and any topics for the next board meeting. Staff will remind everyone of the location for the next board meeting.

***Adjournment**

*ITEMS that may require Board Action

Items on the Consent Agenda generally consist of the following:

- Minutes of previous Board Meeting , Special Board Meeting and/or Study Session
- Right-of-Way Resolutions
- Construction Contracts that have no bidder protest or State Engineer inquiry and meet the following criteria:
 - Low bidder is no more than 15% under state estimate
 - Low bidder is no more than 10% over state estimate
- Programming changes for items that are a part of the approved scope of the project if they exceed 15% or \$200,000, whichever is lesser.

RIGHT OF WAY RESOLUTIONS (action as noted)

*ITEM:3a RES. NO. 2026-06-A-020
 PROJECT: 024 MA 001 F0719 / 010-A(242)T
 HIGHWAY: GATEWAY FREEWAY
 SECTION: S. R. 202L – Ironwood Dr.
 ROUTE NO.: State Route 24
 DISTRICT: Central
 COUNTY: Maricopa
 RECOMMENDATION: Establish new right of way as a state route and state highway to be utilized for soundwall improvements under the above referenced project, necessary to enhance convenience and safety for the traveling public.

*ITEM:3b RES. NO. 2026-06-A-021
 PROJECT: 010 PM 262 F0548 / 010-D(232)S
 HIGHWAY: TUCSON - BENSON
 SECTION: Country Club. & Kino T.I.'s
 ROUTE NO.: Interstate Route 10
 DISTRICT: Southcentral
 COUNTY: Pima
 RECOMMENDATION: Establish additional new right of way as a state route and state highway to accommodate design change and facilitate the construction phase of the above referenced project, necessary for increased capacity and enhance convenience and safety for the traveling public.

*ITEM:3c RES. NO. 2026-06-A-022
 PROJECT: 060 MA 159 F0272 / 060-B(227)T
 HIGHWAY: WICKENBURG - PHOENIX
 SECTION: Indian School Road – 35th Avenue T.I.
 ROUTE NO.: U.S. Route 60
 DISTRICT: Central
 COUNTY: Maricopa
 RECOMMENDATION: Establish new right of way as a state route to be utilized for design change of this heavily traveled traffic interchange under the above referenced project, necessary to enhance convenience and safety for the traveling public.

RIGHT OF WAY RESOLUTIONS (action as noted)

*ITEM:3d RES. NO. 2026-06-A-023
PROJECT: 303L MA 002 H7139 / 303-A(206)N (Phase I)
HIGHWAY: BOB STUMP MEMORIAL PARKWAY
SECTION: I-10 Traffic Interchange (Camelback Rd. – Olive Ave.)
ROUTE NO.: State Route 303 Loop
DISTRICT: Central
COUNTY: Maricopa
DISPOSAL: D-C-112-A
RECOMMENDATION: Abandon to the City of Goodyear, in accordance with that Four-Year Advanced Notice of Abandonment and Pavement Quality Report, dated May 18, 2026, rights of way acquired that are no longer needed for the State Transportation System and can be better managed by the Local Public Agency.

Contracts: (Action as Noted)

Federal-Aid (“A” “B” “T” “D”) projects do not need FHWA concurrence, but must comply with DBE regulations; other projects are subject to FHWA and/or local government concurrence and compliance with DBE regulations.

*ITEM:3e BOARD DISTRICT NO.: 6
 BIDS OPENED: MAY 15, 2026
 HIGHWAY: PRESCOTT – ASH FORK HWY (SR 89)
 SECTION: MP 353.67 TO MP 354.62 (NORTH OF DRAKE)
 COUNTY: YAVAPAI
 ROUTE NO.: SR 89
 PROJECT : TRACS: 089-B(223)T: 089 YV 353 F063401C
 FUNDING: 94.3% FEDS 5.7% STATE
 LOW BIDDER: EARTH RESOURCES CORPORATION
 LOW BID AMOUNT: \$ 2,947,005.00
 DEPARTMENT ESTI-
 MATE: \$ 3,355,118.00
 \$ UNDER ESTIMATE: \$ 3,355,118.00
 % UNDER ESTIMATE: 12.2%
 PROJECT DBE GOAL: 0.0%
 BIDDER DBE PLEDGE: N/A (DBE IFR effective 10/3/25)
 NO. BIDDERS: 4
 RECOMMENDATION: AWARD



Contracts: (Action as Noted)

*ITEM:3f BOARD DISTRICT NO.: 6
 BIDS OPENED: MAY 08, 2026
 HIGHWAY: KINGMAN – WICKENBURG HIGHWAY (US 93)
 SECTION: CHOLLA CANYON RANCH RD TO EAST OLD WIKIEUP HILLSIDE RD
 COUNTY: MOHAVE
 ROUTE NO.: US 93
 PROJECT : TRACS: 093-B(227)T: 093 MO 127 F076001C
 FUNDING: 94.3% FED 5.7% STATE
 LOW BIDDER: FNF CONSTRUCTION, INC.
 LOW BID AMOUNT: \$ 9,631,964.10
 DEPARTMENT ESTI-
 MATE: \$ 11,003.651.20
 \$ UNDER ESTIMATE: \$ 1,371,687.10
 % UNDER ESTIMATE: 12.5%
 PROJECT DBE GOAL: 0.0%
 BIDDER DBE PLEDGE: N/A (DBE IFR effective 10/3/25)
 NO. BIDDERS: 2
 RECOMMENDATION: AWARD

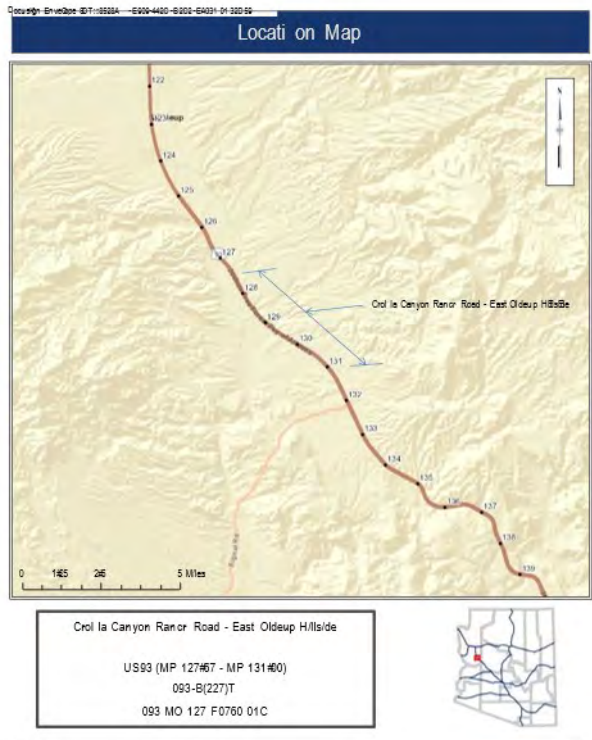

2/23/2025

Contracts: (Action as Noted)

*ITEM:3g BOARD DISTRICT NO.: 6
 BIDS OPENED: MAY 15, 2026
 HIGHWAY: BAGDAD-HILLSIDE HWY (SR 96)
 SECTION: SANTA MARIA RIVER BRIDGE
 COUNTY: YAVAPAI
 ROUTE NO.: SR 96
 PROJECT : TRACS: 096-A(200)T: 096 YV 010 F058401C
 FUNDING: 94.3% FED 5.7% STATE
 LOW BIDDER: FNF CONSTRUCTION, INC.
 LOW BID AMOUNT: \$ 9,480,448.90
 DEPARTMENT ESTI-
 MATE: \$ 9,882,938.70
 \$ UNDER ESTIMATE: \$ 402,489.80
 % UNDER ESTIMATE: 4.1%
 PROJECT DBE GOAL: 0.0%
 BIDDER DBE PLEDGE: N/A (DBE IFR effective 10/3/25)
 NO. BIDDERS: 8
 RECOMMENDATION: AWARD

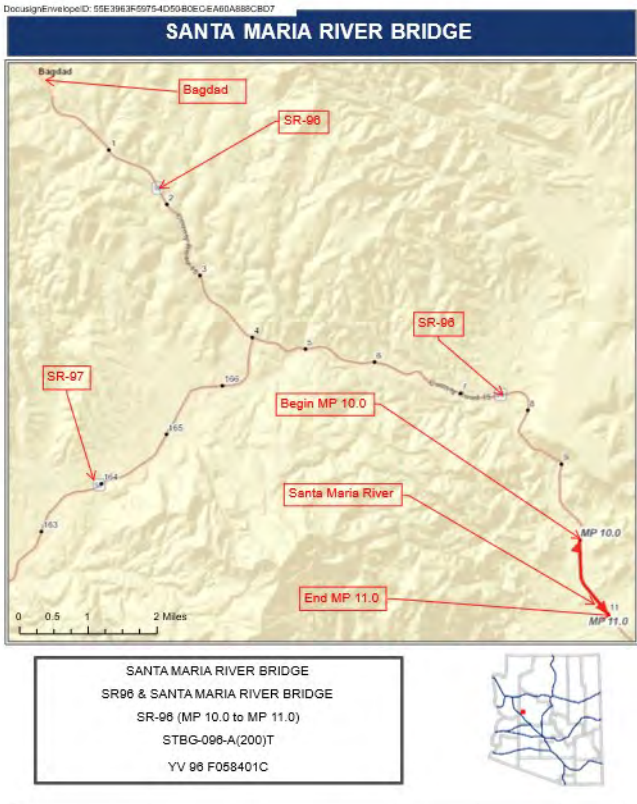

2/23/2026

Contracts: (Action as Noted)

*ITEM:3h BOARD DISTRICT NO.: 4
 BIDS OPENED: MAY 08, 2026
 HIGHWAY: SAFFORD – SPRINGVILLE HIGHWAY (US 191)
 SECTION: US 70 – MP 134
 COUNTY: GRAHAM
 ROUTE NO.: US 191
 PROJECT : TRACS: 191-C(227)T: 191 GH 132 F070801C
 FUNDING: 94.3% FED 5.7% STATE
 LOW BIDDER: SHOW LOW CONSTRUCTION, INC.
 LOW BID AMOUNT: \$ 2,983,902.89
 DEPARTMENT ESTI-
 MATE: \$ 3,186,317.75
 \$ UNDER ESTIMATE: \$ 202,414.86
 % UNDER ESTIMATE: 6.4%
 PROJECT DBE GOAL: 0.0%
 BIDDER DBE PLEDGE: N/A (DBE IFR effective 10/3/25)
 NO. BIDDERS: 3
 RECOMMENDATION: AWARD

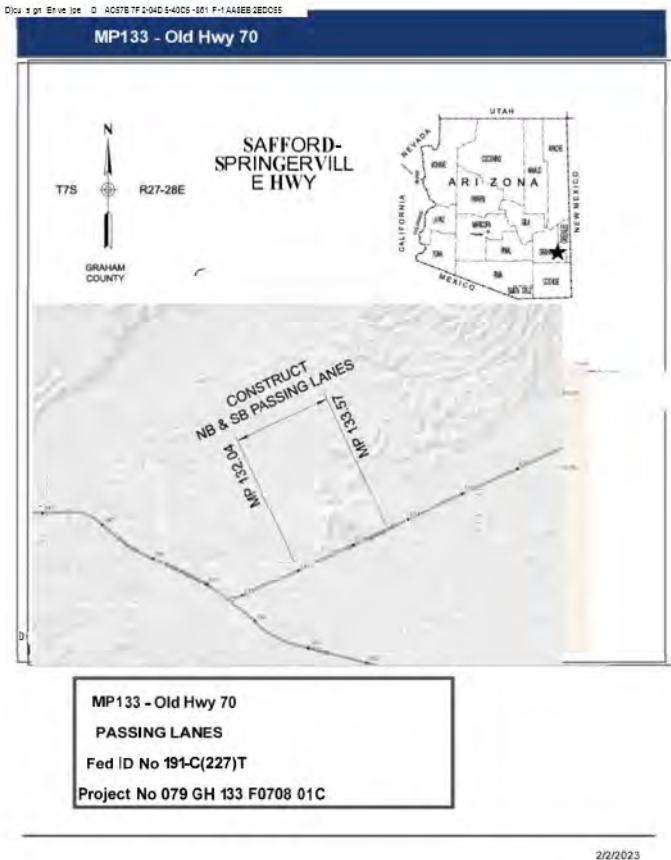

Contracts: (Action as Noted)

*ITEM:3j BOARD DISTRICT NO.: 1
 BIDS OPENED: N/A
 HIGHWAY: EHRENBERG – PHOENIX HIGHWAY
 SECTION: TZN R&W
 COUNTY: MARICOPA
 ROUTE NO.: I-10
 PROJECT : TRACS: 010 MA 086 F077901C
 FUNDING: NHFP & STATE
 LOW BIDDER: RUMMEL CONSTRUCTION, INC.
GMP1 AMOUNT: \$ 1,270,474.00
 DEPARTMENT ESTI-
 MATE: \$ 1,224,561.00
 \$ UNDER ESTIMATE: \$ 45,913.00
 % UNDER ESTIMATE: 3.6%
 PROJECT DBE GOAL: 0.0%
 BIDDER DBE PLEDGE: N/A (DBE IFR effective 10/3/25)
 NO. BIDDERS: **(CMAR PROJECT)**
 RECOMMENDATION: AWARD



June 19, 2026

RES. NO. 2026-06-A-020
PROJECT: 024 MA 000 F0719 / 024-A(201)T
HIGHWAY: GATEWAY FREEWAY
SECTION: S.R. 202L - Ironwood Drive
ROUTE NO.: State Route 24
DISTRICT: Central
COUNTY: Maricopa

REPORT AND RECOMMENDATION

TO THE HONORABLE ARIZONA STATE TRANSPORTATION BOARD:

The Project Delivery and Operations Division has made a thorough investigation concerning the establishment of new right of way as a state route and state highway for the improvement of the Gateway Freeway, State Route 24, within the above referenced project.

The existing right of way was previously established by various resolutions placed of record over the years by the Arizona State Highway Commission, and/or its successor, the Arizona State Transportation Board, which became the governing body of the State Transportation System on July 01, 1974.

New right of way is now needed to be utilized for soundwall improvements under the above referenced project, necessary to enhance convenience and safety for the traveling public.

Accordingly, it is necessary to acquire and establish the new right of way as a state route and state highway, and that access be controlled as necessary for this improvement project.

The new right of way to be established as a state route and state highway and acquired for this improvement, to include access control as necessary, is depicted in Appendix "A" and delineated on maps and plans on file in the office of the State Engineer, Project Delivery and Operations Division, Phoenix, Arizona, entitled: "Right of Way Plans of the GATEWAY FREEWAY, Ellsworth Road - Ironwood Road, Project 024 MA 001 H8915 / 024-A(201)T".

June 19, 2026

RES. NO. 2026-06-A-020
PROJECT: 024 MA 000 F0719 / 024-A(201)T
HIGHWAY: GATEWAY FREEWAY
SECTION: S.R. 202L - Ironwood Drive
ROUTE NO.: State Route 24
DISTRICT: Central
COUNTY: Maricopa

In the interest of public safety, necessity and convenience, I recommend that the new right of way depicted in Appendix "A" be established as a state route and state highway, and that access is controlled.

I recommend the acquisition of the new right of way, pursuant to Arizona Revised Statutes §§ 28-7092 and 28-7094, as an estate in fee, or such other interest as is required, including advance, future and early acquisition, access rights, exchanges or donations, haul roads, material for construction, and various easements in any property necessary for or incidental to the improvements, as delineated on said maps and plans.

I further recommend the immediate establishment of existing county, town and city roadways into the state highway system as a controlled access state route and state highway, which are necessary for or incidental to the improvement as delineated on said maps and plans, to be effective upon signing of this recommendation. This resolution is considered the conveying document for such existing county, town and city roadways; and no further conveyance is legally required.

June 19, 2026

RES. NO. 2026-06-A-020
PROJECT: 024 MA 000 F0719 / 024-A(201)T
HIGHWAY: GATEWAY FREEWAY
SECTION: S.R. 202L - Ironwood Drive
ROUTE NO.: State Route 24
DISTRICT: Central
COUNTY: Maricopa

Pursuant to Arizona Revised Statutes §28-7046, I recommend the adoption of a resolution making this recommendation effective.

Respectfully submitted,

AUDRA MERRICK, P. E., Deputy Director
for Transportation / State Engineer
Arizona Department of Transportation

ARIZONA DEPARTMENT OF TRANSPORTATION
205 South 17th Avenue
R/W Titles Section, MD 612E
Phoenix, Arizona 85007-3212

June 19, 2026

RES. NO. 2026-06-A-020
PROJECT: 024 MA 000 F0719 / 024-A(201)T
HIGHWAY: GATEWAY FREEWAY
SECTION: S.R. 202L - Ironwood Drive
ROUTE NO.: State Route 24
DISTRICT: Central
COUNTY: Maricopa

RESOLUTION OF ESTABLISHMENT

AUDRA MERRICK, Deputy Director for Transportation and State Engineer of the Arizona Department of Transportation, on June 19, 2026, presented and filed with the Arizona State Transportation Board her written report under Arizona Revised Statutes §28-7046, recommending the acquisition and establishment of new right of way as a state route and state highway for the improvement of the Gateway Freeway, State Route 24, as set forth in the above referenced project.

New right of way is now needed to be utilized for soundwall improvements under the above referenced project, necessary to enhance convenience and safety for the traveling public.

Accordingly, it is necessary to acquire and establish the new right of way as a state route and state highway, and that access be controlled as necessary for this improvement project.

The new right of way to be established as a state route and state highway and acquired for this improvement, to include access control as necessary, is depicted in Appendix "A" and delineated on maps and plans on file in the office of the State Engineer, Project Delivery and Operations Division, Phoenix, Arizona, entitled: "Right of Way Plans of the GATEWAY FREEWAY, Ellsworth Road - Ironwood Road, Project 024 MA 001 H8915 / 024-A(201)T".

June 19, 2026

RES. NO. 2026-06-A-020
PROJECT: 024 MA 000 F0719 / 024-A(201)T
HIGHWAY: GATEWAY FREEWAY
SECTION: S.R. 202L - Ironwood Drive
ROUTE NO.: State Route 24
DISTRICT: Central
COUNTY: Maricopa

WHEREAS establishment as a state route and state highway, and acquisition of the new right of way as an estate in fee, or such other interest as required, is necessary for this improvement, with authorization pursuant to Arizona Revised Statutes §§ 28-7092 and 28-7094 to include advance, future and early acquisition, access rights, exchanges or donations, haul roads, material for construction, and various easements in any property necessary for or incidental to the improvements, as delineated on said maps and plans; and

WHEREAS because of these premises, this Board finds public safety, necessity and convenience require the recommended acquisition and establishment of the new right of way as a state route and state highway needed for this improvement and that access to the highway be controlled as delineated on the maps and plans; and

WHEREAS the existing county, town or city roadways, as delineated on said maps and plans, are hereby established as a state route and state highway by this resolution action; and this resolution is considered the conveying document for such existing county, town and city roadways; and no further conveyance is legally required; therefore, be it

RESOLVED that the recommendation of the Deputy Director is adopted and made part of this resolution; be it further

RESOLVED that the right of way depicted in Appendix "A" is hereby designated a state route and state highway, to include any existing county, town or city roadways, and that ingress and egress to and from the highway and to and from abutting, adjacent, or other lands be denied, controlled or regulated as delineated on said maps and plans. Where no access is shown, none will be allowed to exist; be it further

June 19, 2026

RES. NO. 2026-06-A-020
PROJECT: 024 MA 000 F0719 / 024-A(201)T
HIGHWAY: GATEWAY FREEWAY
SECTION: S.R. 202L - Ironwood Drive
ROUTE NO.: State Route 24
DISTRICT: Central
COUNTY: Maricopa

RESOLVED that the Deputy Director is hereby authorized to acquire by lawful means, pursuant to Arizona Revised Statutes §§ 28-7092 and 28-7094, an estate in fee, or such other interest as is required, to include advance, future and early acquisition, access rights, exchanges or donations, haul roads, material for construction, and various easements in any property necessary for or incidental to the improvements, as delineated on said maps and plans; be it further

RESOLVED that written notice has been provided to the County Board of Supervisors in accordance with Arizona Revised Statutes § 28-7043, and to the affected governmental jurisdictions whose local existing roadways are being immediately established as a state route and state highway herein; and that this resolution is the conveying document for such existing county, town and city roadways; and no further conveyance is legally required; be it further

RESOLVED that the Deputy Director secure an appraisal of the property to be acquired, including access rights, and that necessary parties be compensated - with the exception of any existing county, town or city roadways being immediately established herein as a state route and state highway. Upon failure to acquire said lands by other lawful means, the Deputy Director is authorized to initiate condemnation proceedings.

June 19, 2026

RES. NO. 2026-06-A-020
PROJECT: 024 MA 000 F0719 / 024-A(201)T
HIGHWAY: GATEWAY FREEWAY
SECTION: S.R. 202L - Ironwood Drive
ROUTE NO.: State Route 24
DISTRICT: Central
COUNTY: Maricopa

CERTIFICATION

I, AUDRA MERRICK, as Deputy Director for Transportation and State Engineer of the Arizona Department of Transportation, do hereby certify that the foregoing is a true and correct copy from the minutes of the Arizona State Transportation Board, made in official session on June 19, 2026.

IN WITNESS WHEREOF I have hereunto set my hand and the official seal of the Arizona State Transportation Board on June 19, 2026.

AUDRA MERRICK, P. E., Deputy Director
for Transportation / State Engineer
Arizona Department of Transportation

Seal

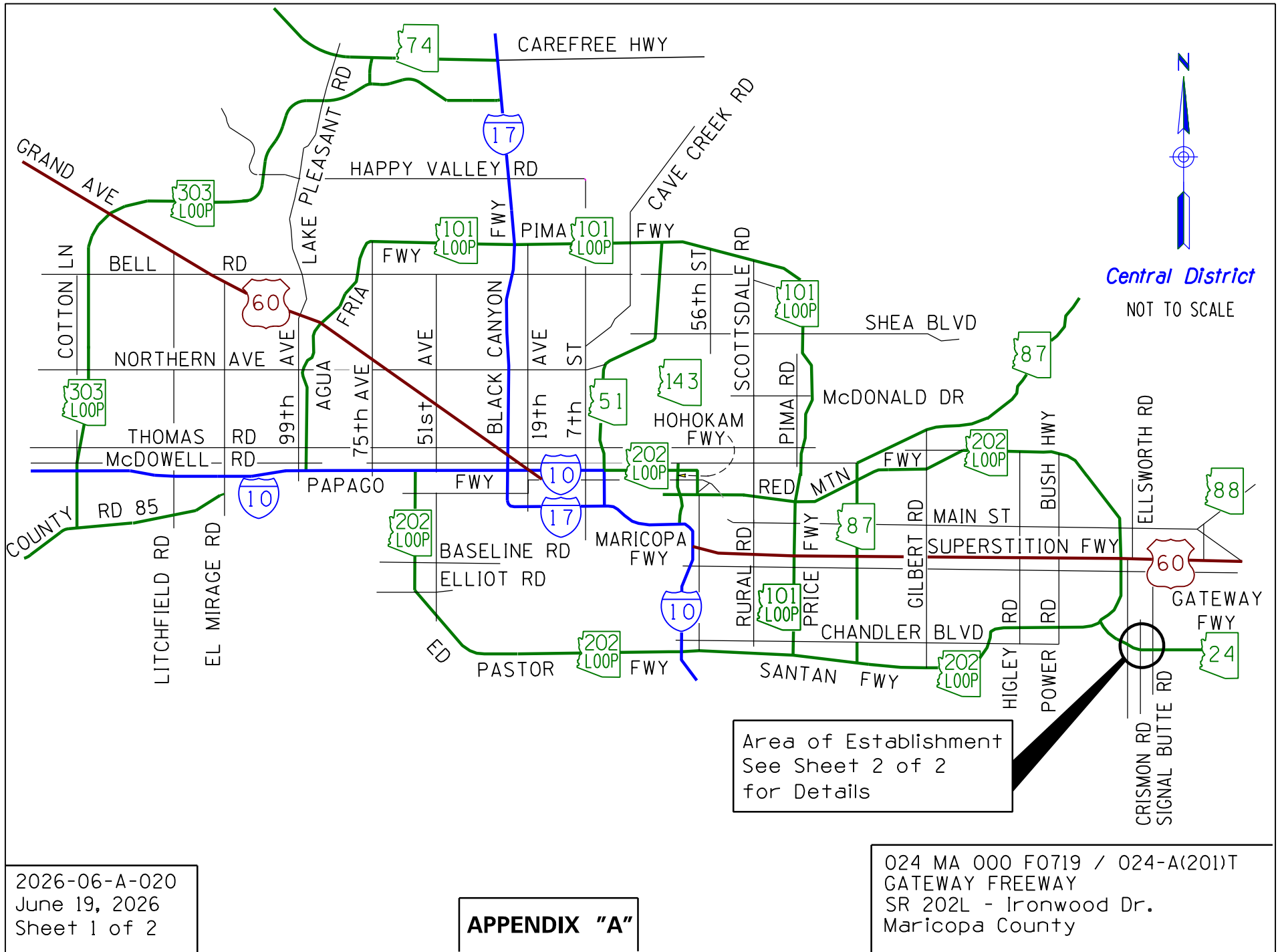

Area of Establishment
See Sheet 2 of 2
for Details

2026-06-A-020
June 19, 2026
Sheet 1 of 2

APPENDIX "A"

024 MA 000 F0719 / 024-A(201)T
GATEWAY FREEWAY
SR 202L - Ironwood Dr.
Maricopa County

CITY

Warner Rd

S.R. 202L

GATEWAY

Ellsworth Rd
Section Line

Crismon Rd
Section Line

Signal Butte Rd
Section Line

Section Line

Meridian Rd
Township Line

Ironwood Dr



Central District

NOT TO SCALE

R. 7 E.
R. 8 E.

Sossaman Rd (Extension)
Section Line

Ray Rd

Hawes Rd (Extension)
Section Line

OF

FREEWAY

S.R. 24

222nd St

Section Line

Mountain Rd

MESA

Williams Field Rd

32

33

34

35

36

31

Pecos Rd

T. 1 S.
T. 2 S.

Township Line

T. 1 S.
T. 2 S.

Area of 
Establishment

APPENDIX "A"

2026-06-A-020
June 19, 2026
Sheet 2 of 2

024 MA 000 F0719 / 024-A(201)T
GATEWAY FREEWAY
SR 202L - Ironwood Dr.
Maricopa County

June 19, 2026

RES. NO. 2026-06-A-021
PROJECT: 010 PM 262 F0548 / 010-E(232)S
HIGHWAY: TUCSON - BENSON
SECTION: Country Club & Kino T.I.'s
ROUTE NO.: Interstate Route 10
DISTRICT: Southcentral
COUNTY: Pima

REPORT AND RECOMMENDATION

TO THE HONORABLE ARIZONA STATE TRANSPORTATION BOARD:

The Project Delivery and Operations Division has made a thorough investigation concerning the establishment of new right of way as a state route and state highway for the improvement of the Tucson - Benson Highway, Interstate Route 10, within the above referenced project.

The existing right of way was previously established by various resolutions placed of record over the years by the Arizona State Highway Commission, and/or its successor, the Arizona State Transportation Board, which became the governing body of the State Transportation System on July 01, 1974.

New right of way is now needed to accommodate design change and facilitate the construction phase of the above referenced project, necessary for increased capacity and enhance convenience and safety for the traveling public.

Accordingly, it is necessary to acquire and establish the new right of way as a state route and state highway, and that access be controlled as necessary for this improvement project.

The new right of way to be established as a state route and state highway and acquired for this improvement, to include access control as necessary, is depicted in Appendix "A" and delineated on maps and plans on file in the office of the State Engineer, Project Delivery and Operations Division, Phoenix, Arizona, entitled: "Right of Way Plans of the TUCSON - BENSON HIGHWAY, Country Club & Kino T.I., Project 010 PM 262 F0548 / 010-E(232)S".

June 19, 2026

RES. NO. 2026-06-A-021
PROJECT: 010 PM 262 F0548 / 010-E(232)S
HIGHWAY: TUCSON - BENSON
SECTION: Country Club & Kino T.I.'s
ROUTE NO.: Interstate Route 10
DISTRICT: Southcentral
COUNTY: Pima

In the interest of public safety, necessity and convenience, I recommend that the new right of way depicted in Appendix "A" be established as a state route and state highway, and that access is controlled.

I recommend the acquisition of the new right of way, pursuant to Arizona Revised Statutes §§ 28-7092 and 28-7094, as an estate in fee, or such other interest as is required, including advance, future and early acquisition, access rights, exchanges or donations, haul roads, material for construction, and various easements in any property necessary for or incidental to the improvements, as delineated on said maps and plans.

I further recommend the immediate establishment of existing county, town and city roadways into the state highway system as a controlled access state route and state highway, which are necessary for or incidental to the improvement as delineated on said maps and plans, to be effective upon signing of this recommendation. This resolution is considered the conveying document for such existing county, town and city roadways; and no further conveyance is legally required.

June 19, 2026

RES. NO. 2026-06-A-021
PROJECT: 010 PM 262 F0548 / 010-E(232)S
HIGHWAY: TUCSON - BENSON
SECTION: Country Club & Kino T.I.'s
ROUTE NO.: Interstate Route 10
DISTRICT: Southcentral
COUNTY: Pima

Pursuant to Arizona Revised Statutes §28-7046, I recommend the adoption of a resolution making this recommendation effective.

Respectfully submitted,

AUDRA MERRICK, P. E., Deputy Director
for Transportation / State Engineer
Arizona Department of Transportation

ARIZONA DEPARTMENT OF TRANSPORTATION
205 South 17th Avenue
R/W Titles Section, MD 612E
Phoenix, Arizona 85007-3212

June 19, 2026

RES. NO. 2026-06-A-021
PROJECT: 010 PM 262 F0548 / 010-E(232)S
HIGHWAY: TUCSON - BENSON
SECTION: Country Club & Kino T.I.'s
ROUTE NO.: Interstate Route 10
DISTRICT: Southcentral
COUNTY: Pima

RESOLUTION OF ESTABLISHMENT

AUDRA MERRICK, Deputy Director for Transportation and State Engineer of the Arizona Department of Transportation, on June 19, 2026, presented and filed with the Arizona State Transportation Board her written report under Arizona Revised Statutes §28-7046, recommending the acquisition and establishment of new right of way as a state route and state highway for the improvement of the Tucson - Benson Highway, Interstate Route 10, as set forth in the above referenced project.

New right of way is now needed to accommodate design change and facilitate the construction phase of the above referenced project, necessary for increased capacity and enhance convenience and safety for the traveling public.

Accordingly, it is necessary to acquire and establish the new right of way as a state route and state highway, and that access be controlled as necessary for this improvement project.

The new right of way to be established as a state route and state highway and acquired for this improvement, to include access control as necessary, is depicted in Appendix "A" and delineated on maps and plans on file in the office of the State Engineer, Project Delivery and Operations Division, Phoenix, Arizona, entitled: "Right of Way Plans of the TUCSON - BENSON HIGHWAY, Country Club & Kino T.I., Project 010 PM 262 F0548 / 010-E(232)S".

June 19, 2026

RES. NO. 2026-06-A-021
PROJECT: 010 PM 262 F0548 / 010-E(232)S
HIGHWAY: TUCSON - BENSON
SECTION: Country Club & Kino T.I.'s
ROUTE NO.: Interstate Route 10
DISTRICT: Southcentral
COUNTY: Pima

WHEREAS establishment as a state route and state highway, and acquisition of the new right of way as an estate in fee, or such other interest as required, is necessary for this improvement, with authorization pursuant to Arizona Revised Statutes §§ 28-7092 and 28-7094 to include advance, future and early acquisition, access rights, exchanges or donations, haul roads, material for construction, and various easements in any property necessary for or incidental to the improvements, as delineated on said maps and plans; and

WHEREAS because of these premises, this Board finds public safety, necessity and convenience require the recommended acquisition and establishment of the new right of way as a state route and state highway needed for this improvement and that access to the highway be controlled as delineated on the maps and plans; and

WHEREAS the existing county, town or city roadways, as delineated on said maps and plans, are hereby established as a state route and state highway by this resolution action; and this resolution is considered the conveying document for such existing county, town and city roadways; and no further conveyance is legally required; therefore, be it

RESOLVED that the recommendation of the Deputy Director is adopted and made part of this resolution; be it further

RESOLVED that the right of way depicted in Appendix "A" is hereby designated a state route and state highway, to include any existing county, town or city roadways, and that ingress and egress to and from the highway and to and from abutting, adjacent, or other lands be denied, controlled or regulated as delineated on said maps and plans. Where no access is shown, none will be allowed to exist; be it further

June 19, 2026

RES. NO. 2026-06-A-021
PROJECT: 010 PM 262 F0548 / 010-E(232)S
HIGHWAY: TUCSON - BENSON
SECTION: Country Club & Kino T.I.'s
ROUTE NO.: Interstate Route 10
DISTRICT: Southcentral
COUNTY: Pima

RESOLVED that the Deputy Director is hereby authorized to acquire by lawful means, pursuant to Arizona Revised Statutes §§ 28-7092 and 28-7094, an estate in fee, or such other interest as is required, to include advance, future and early acquisition, access rights, exchanges or donations, haul roads, material for construction, and various easements in any property necessary for or incidental to the improvements, as delineated on said maps and plans; be it further

RESOLVED that written notice has been provided to the County Board of Supervisors in accordance with Arizona Revised Statutes § 28-7043, and to the affected governmental jurisdictions whose local existing roadways are being immediately established as a state route and state highway herein; and that this resolution is the conveying document for such existing county, town and city roadways; and no further conveyance is legally required; be it further

RESOLVED that the Deputy Director secure an appraisal of the property to be acquired, including access rights, and that necessary parties be compensated - with the exception of any existing county, town or city roadways being immediately established herein as a state route and state highway. Upon failure to acquire said lands by other lawful means, the Deputy Director is authorized to initiate condemnation proceedings.

June 19, 2026

RES. NO. 2026-06-A-021
PROJECT: 010 PM 262 F0548 / 010-E(232)S
HIGHWAY: TUCSON - BENSON
SECTION: Country Club & Kino T.I.'s
ROUTE NO.: Interstate Route 10
DISTRICT: Southcentral
COUNTY: Pima

CERTIFICATION

I, AUDRA MERRICK, as Deputy Director for Transportation and State Engineer of the Arizona Department of Transportation, do hereby certify that the foregoing is a true and correct copy from the minutes of the Arizona State Transportation Board, made in official session on June 19, 2026.

IN WITNESS WHEREOF I have hereunto set my hand and the official seal of the Arizona State Transportation Board on June 19, 2026.

AUDRA MERRICK, P. E., Deputy Director
for Transportation / State Engineer
Arizona Department of Transportation

Seal

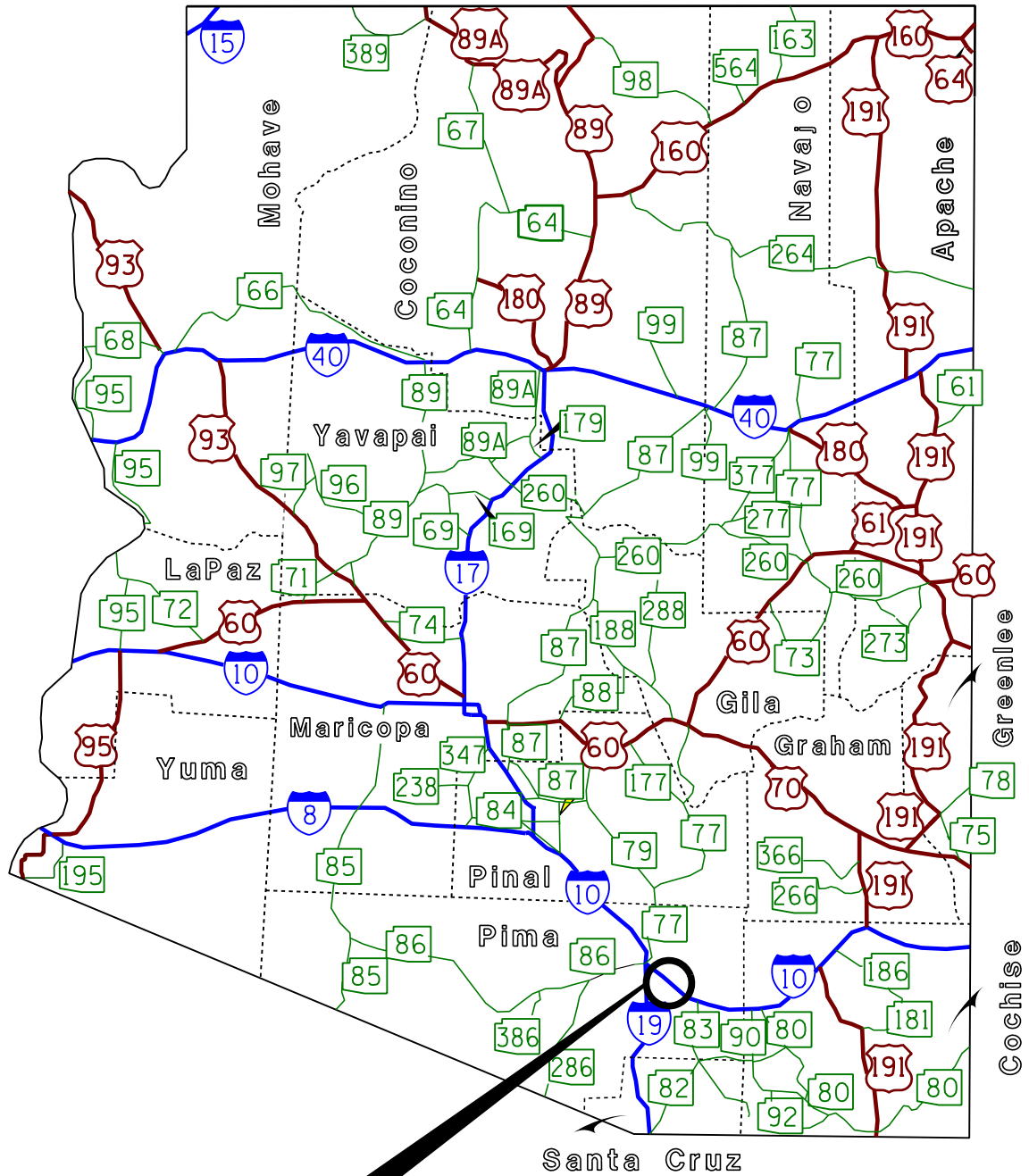
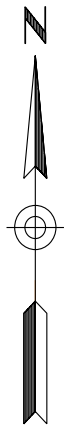

Area of Establishment
See Sheet 2 of 2
for Details

2026-06-A-021
June 19, 2026
Sheet 1 of 2

APPENDIX "A"

010 PM 262 F0548 / 010-E(232)S
TUCSON - BENSON HIGHWAY
Country Club & Kino T.I.'s
Pima County

CITY

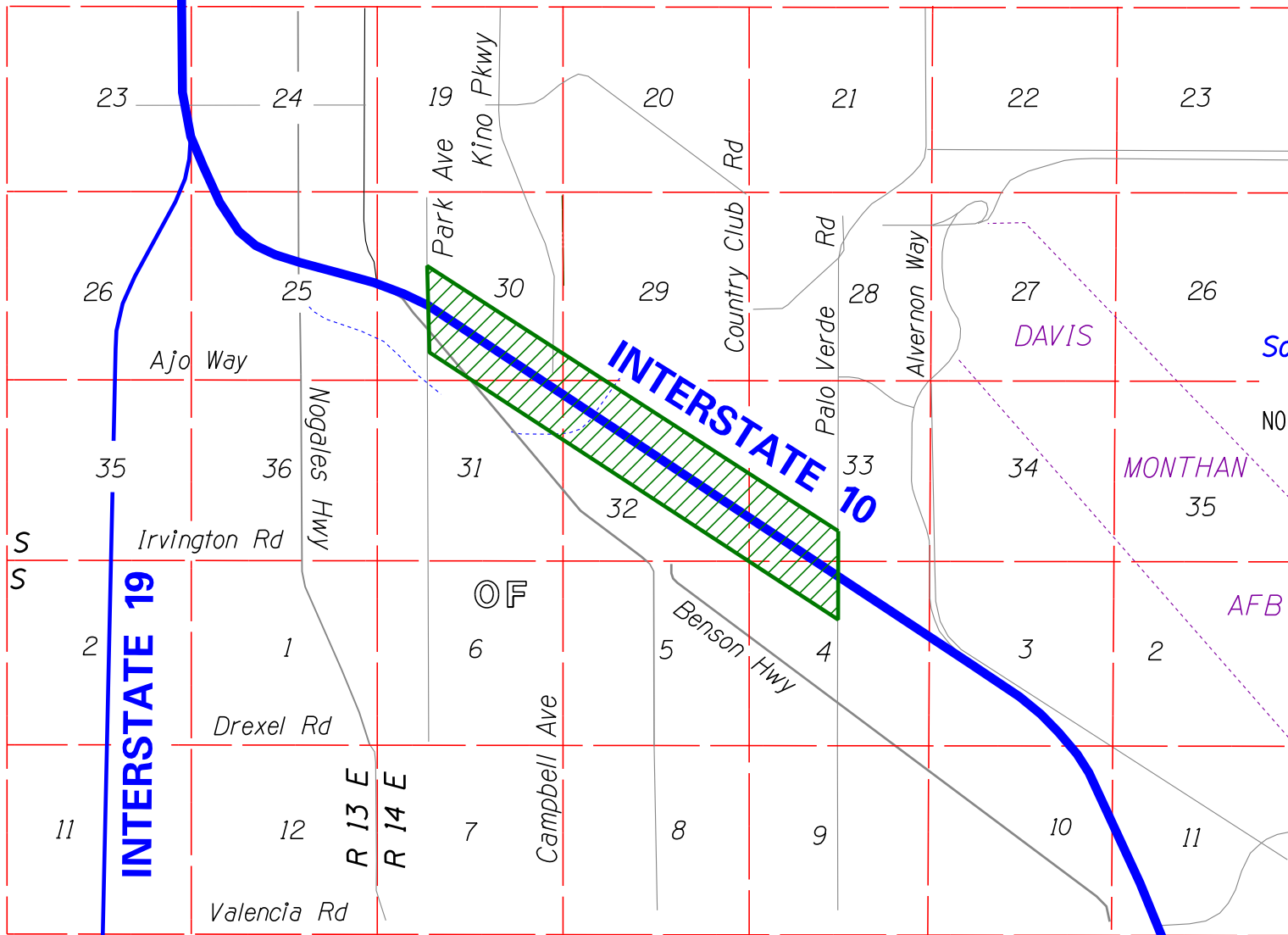

Southcentral District
NOT TO SCALE

T 14 S
T 15 S

TUCSON

Area of 
Establishment

APPENDIX "A"

010 PM 262 F0548 / 010-E(232)S
TUCSON - BENSON HIGHWAY
Country Club & Kino T.I.'s
Pima County

2026-06-A-021
June 19, 2026
Sheet 2 of 2

June 19, 2026

RES. NO. 2026-06-A-022
PROJECT: 060 MA 159 F0272 / 060-B(227)T
HIGHWAY: WICKENBURG - PHOENIX
SECTION: Indian School Road - 35th Avenue T. I.
ROUTE NO.: U. S. Route 60
DISTRICT: Central
COUNTY: Maricopa

REPORT AND RECOMMENDATION

TO THE HONORABLE ARIZONA STATE TRANSPORTATION BOARD:

The Project Delivery and Operations Division has made a thorough investigation concerning the establishment and improvement of the Wickenburg - Phoenix Highway, U. S. Route 60, within the above referenced project.

The existing right of way was previously established by various resolutions placed of record over the years by the Arizona State Highway Commission, and/or its successor, the Arizona State Transportation Board, which became the governing body of the State Transportation System on July 01, 1974.

New right of way is now needed to be utilized for design change of this heavily traveled traffic interchange, necessary to enhance convenience and safety for the traveling public.

Accordingly, it is necessary to acquire and establish the new right of way as a state route, and that access be controlled as necessary for this improvement project.

June 19, 2026

RES. NO. 2026-06-A-022
PROJECT: 060 MA 159 F0272 / 060-B(227)T
HIGHWAY: WICKENBURG - PHOENIX
SECTION: Indian School Road - 35th Avenue T. I.
ROUTE NO.: U. S. Route 60
DISTRICT: Central
COUNTY: Maricopa

The new right of way to be established as a state route and acquired for this improvement, including access control as necessary, is depicted in Appendix "A" and delineated on maps and plans on file in the office of the State Engineer, Project Delivery and Operations Division, Phoenix, Arizona, entitled: "Stage III Design Plans, dated May 2025 of the WICKENBURG - PHOENIX HIGHWAY US 60, 35th Ave / Indian School Rd Traffic Interchange, Project 060 MA 159 F0272 01C / 060-B(227)T".

In the interest of public safety, necessity and convenience, I recommend that the new right of way depicted in Appendix "A" be established and improved as a state route, that access be controlled, and that the new right of way shall be established as a state highway prior to construction.

I further recommend the acquisition of the new right of way pursuant to Arizona Revised Statutes §§ 28-7092 and 28-7094, an estate in fee, or such other interest as required, including advance, future and early acquisition, access rights, exchanges, donations, haul roads, material for construction, and various easements in any property necessary for or incidental to the improvements, as delineated on said maps and plans.

June 19, 2026

RES. NO. 2026-06-A-022
PROJECT: 060 MA 159 F0272 / 060-B(227)T
HIGHWAY: WICKENBURG - PHOENIX
SECTION: Indian School Road - 35th Avenue T. I.
ROUTE NO.: U. S. Route 60
DISTRICT: Central
COUNTY: Maricopa

Pursuant to Arizona Revised Statutes §28-7046, I recommend the adoption of a resolution making this recommendation effective.

Respectfully submitted,

AUDRA MERRICK, P. E., Deputy Director
for Transportation / State Engineer
Arizona Department of Transportation

ARIZONA DEPARTMENT OF TRANSPORTATION
205 South 17th Avenue
R/W Titles Section, MD 612E
Phoenix, Arizona 85007-3212

June 19, 2026

RES. NO. 2026-06-A-022
PROJECT: 060 MA 159 F0272 / 060-B(227)T
HIGHWAY: WICKENBURG - PHOENIX
SECTION: Indian School Road - 35th Avenue T. I.
ROUTE NO.: U. S. Route 60
DISTRICT: Central
COUNTY: Maricopa

RESOLUTION OF ESTABLISHMENT

AUDRA MERRICK, Deputy Director for Transportation and State Engineer of the Arizona Department of Transportation, on June 19, 2026, presented and filed with the Arizona State Transportation Board her written report under Arizona Revised Statutes §28-7046, recommending the acquisition and establishment of new right of way for the improvement of the Wickenburg - Phoenix Highway, U. S. Route 60, as set forth in the above referenced project.

New right of way is now needed to be utilized for design change of this heavily traveled traffic interchange, necessary to enhance convenience and safety for the traveling public.

Accordingly, it is necessary to acquire and establish the new right of way as a state route, and that access be controlled as necessary for this improvement project.

The new right of way to be established as a state route and acquired for this improvement, to include access control as necessary, is depicted in Appendix "A" and delineated on maps and plans on file in the office of the State Engineer, Project Delivery and Operations Division, Phoenix, Arizona, entitled: "Stage III Design Plans, dated May 2025 of the WICKENBURG - PHOENIX HIGHWAY US 60, 35th Ave / Indian School Rd Traffic Interchange, Project 060 MA 159 F0272 01C / 060-B(227)T".

June 19, 2026

RES. NO. 2026-06-A-022
PROJECT: 060 MA 159 F0272 / 060-B(227)T
HIGHWAY: WICKENBURG - PHOENIX
SECTION: Indian School Road - 35th Avenue T. I.
ROUTE NO.: U. S. Route 60
DISTRICT: Central
COUNTY: Maricopa

WHEREAS establishment as a state route, and acquisition of the new right of way as an estate in fee, or such other interest as required, is necessary for this improvement, with authorization pursuant to Arizona Revised Statutes §§28-7092 and 28-7094 to include advance, future and early acquisition, access rights, exchanges or donations, haul roads, material for construction, and various easements in any property necessary for or incidental to the improvements, as delineated on said maps and plans; and

WHEREAS because of these premises, this Board finds public safety, necessity and convenience require the recommended acquisition and establishment of the new right of way needed for this improvement, and that access to the highway be controlled as delineated on the maps and plans; therefore, be it

RESOLVED that the recommendation of the Deputy Director is adopted and made part of this resolution; be it further

RESOLVED that the new right of way as depicted in Appendix "A" is hereby designated a controlled access state route, that the new right of way shall be established as a state highway prior to construction, and that ingress and egress to and from the highway and to and from abutting, adjacent, or other lands be denied, controlled or regulated as indicated by the maps and plans. Where no access is shown, none will be allowed to exist; be it further

June 19, 2026

RES. NO. 2026-06-A-022
PROJECT: 060 MA 159 F0272 / 060-B(227)T
HIGHWAY: WICKENBURG - PHOENIX
SECTION: Indian School Road - 35th Avenue T. I.
ROUTE NO.: U. S. Route 60
DISTRICT: Central
COUNTY: Maricopa

RESOLVED that the Deputy Director is hereby authorized to acquire by lawful means pursuant to Arizona Revised Statutes §§ 28-7092 and 28-7094, an estate in fee, or such other interest as required, to include advance, future and early acquisition, access rights, exchanges or donations, haul roads, material for construction, and various easements in any property necessary for or incidental to the improvements, as delineated on said maps and plans; be it further

RESOLVED that the Deputy Director secure an appraisal of the property to be acquired and that necessary parties be compensated. Upon failure to acquire said lands by other lawful means, the Deputy Director is authorized to initiate condemnation proceedings.

June 19, 2026

RES. NO. 2026-06-A-022
PROJECT: 060 MA 159 F0272 / 060-B(227)T
HIGHWAY: WICKENBURG - PHOENIX
SECTION: Indian School Road - 35th Avenue T. I.
ROUTE NO.: U. S. Route 60
DISTRICT: Central
COUNTY: Maricopa

CERTIFICATION

I, AUDRA MERRICK, as Deputy Director for Transportation and State Engineer of the Arizona Department of Transportation, do hereby certify that the foregoing is a true and correct copy from the minutes of the Arizona State Transportation Board, made in official session on June 19, 2026.

IN WITNESS WHEREOF I have hereunto set my hand and the official seal of the Arizona State Transportation Board on June 19, 2026.

AUDRA MERRICK, P. E., Deputy Director
for Transportation / State Engineer
Arizona Department of Transportation

Seal

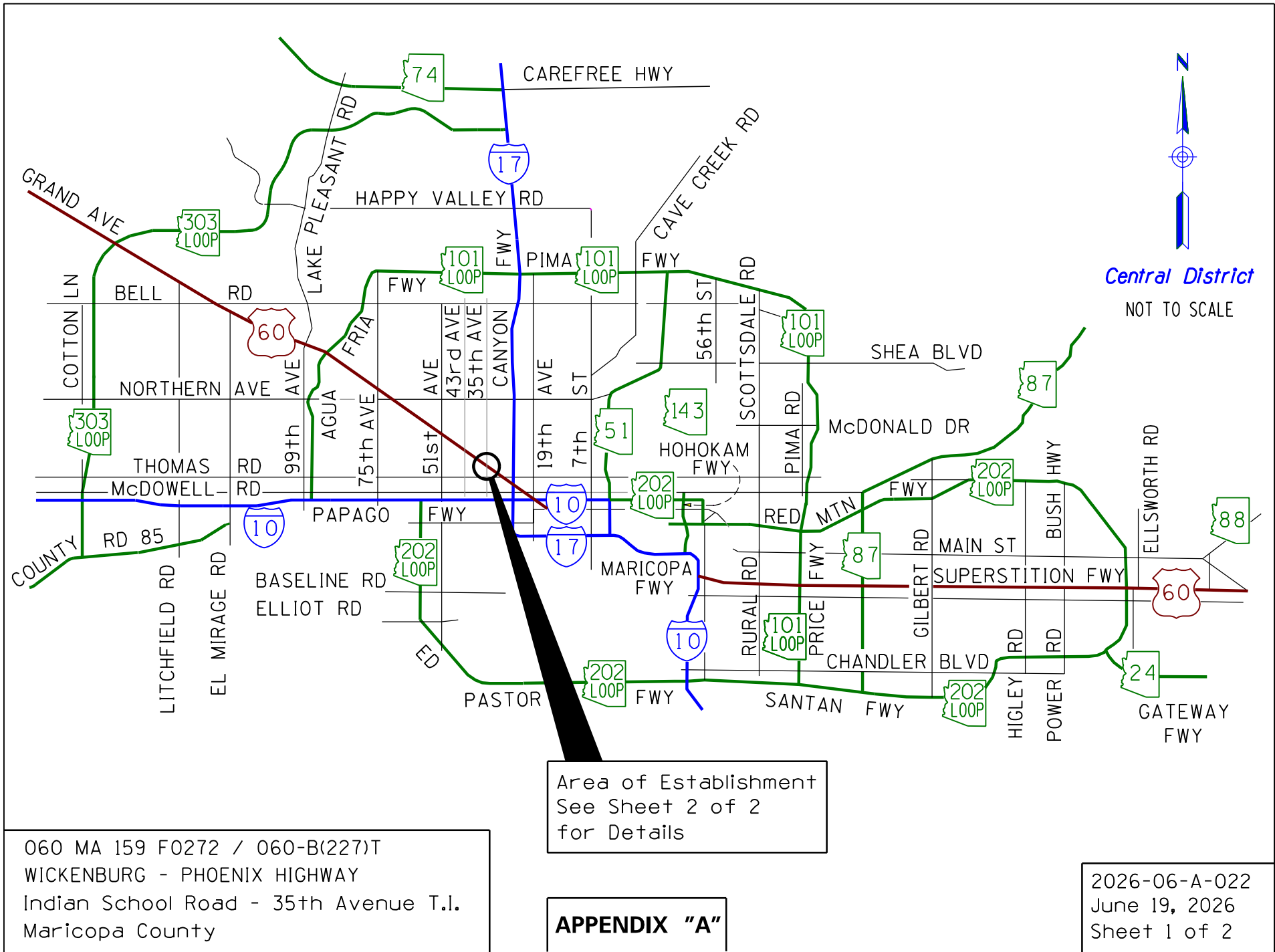

Area of Establishment
See Sheet 2 of 2
for Details

060 MA 159 F0272 / 060-B(227)T
WICKENBURG - PHOENIX HIGHWAY
Indian School Road - 35th Avenue T.I.
Maricopa County

APPENDIX "A"

2026-06-A-022
June 19, 2026
Sheet 1 of 2

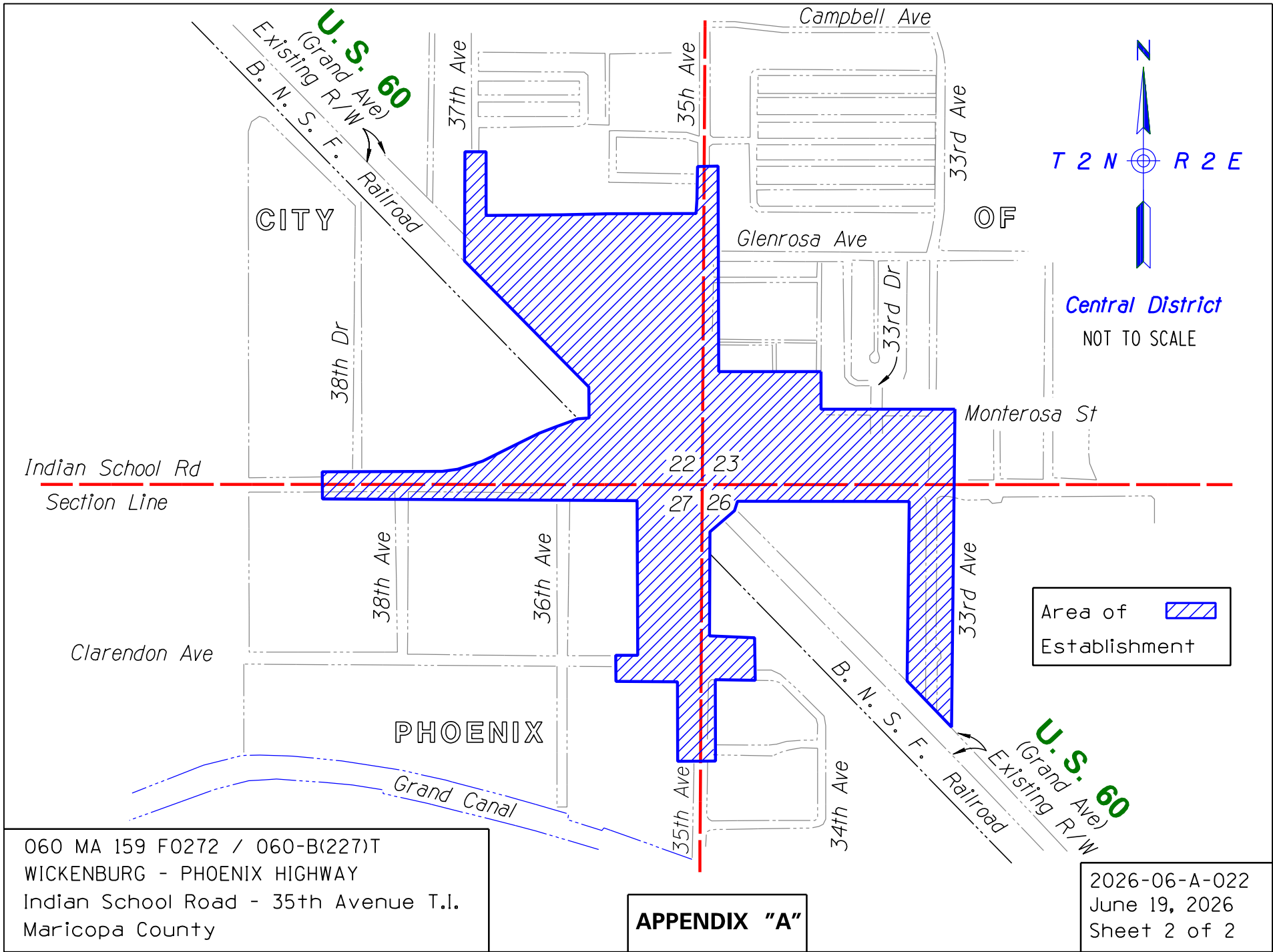

060 MA 159 F0272 / 060-B(227)T
 WICKENBURG - PHOENIX HIGHWAY
 Indian School Road - 35th Avenue T.I.
 Maricopa County

APPENDIX "A"

2026-06-A-022
 June 19, 2026
 Sheet 2 of 2

June 19, 2026

RES. NO. 2026-06-A-023
PROJECT: 303L MA 002 H7139 / 303-A(206)N (Phase I)
HIGHWAY: BOB STUMP MEMORIAL PARKWAY
SECTION: I-10 Traffic Interchange (Camelback Rd. - Olive Ave.)
ROUTE NO.: State Route 303L
DISTRICT: Central
COUNTY: Maricopa
DISPOSAL: D-C-112-A

REPORT AND RECOMMENDATION

TO THE HONORABLE ARIZONA STATE TRANSPORTATION BOARD:

The Project Delivery and Operations Division has made a thorough investigation concerning the abandonment of certain right of way acquired for Bob Stump Memorial Parkway within the above referenced project.

The right of way to be abandoned was previously established by various resolutions placed of record over the years by the Arizona State Highway Commission, and/or its successor, the Arizona State Transportation Board, which became the governing body of the State Transportation System on July 01, 1974.

The right of way to be abandoned is no longer needed for state transportation purposes. The City of Goodyear has agreed to accept jurisdiction, ownership and maintenance responsibilities for the right of way in accordance with that certain Waiver of Four-Year Advance Notice of Abandonment and Pavement Quality Report, dated May 18, 2026, executed pursuant to the provisions of Arizona Revised Statutes § 28-7209.

Accordingly, I recommend that the State's interest in the right of way be abandoned, as depicted in the attached Appendix "A" and on the maps and plans of the above referenced project.

June 19, 2026

RES. NO. 2026-06-A-023
PROJECT: 303L MA 002 H7139 / 303-A(206)N (Phase I)
HIGHWAY: BOB STUMP MEMORIAL PARKWAY
SECTION: I-10 Traffic Interchange (Camelback Rd. - Olive Ave.)
ROUTE NO.: State Route 303L
DISTRICT: Central
COUNTY: Maricopa
DISPOSAL: D-C-112-A

The right of way to be abandoned is delineated on the maps and plans on file in the office of the State Engineer, Project Delivery and Operations Division, Phoenix, Arizona, entitled: "Right of Way Plans of the BOB STUMP MEMORIAL PARKWAY, I-10 Traffic Interchange, Project 303L MA 002 H7139 01R / 303-A(206)N (Phase I)", and is shown in Appendix "A" attached hereto.

I further recommend that the right of way depicted in Appendix "A" be removed from the State Highway System and abandoned to the City of Goodyear, in accordance with that certain Waiver of Four-Year Advance Notice of Abandonment and Pavement Quality Report, dated May 18, 2026, and as provided in Arizona Revised Statutes §§28-7207 and 28-7209; subject to the retention of existing access control and all other currently existing facilities and structures of the State Transportation System, if any; and subject to the reservation of a perpetual easement for ingress, egress and maintenance of said existing facilities and structures, if any, including, but not limited to: said access control, soundwalls, drainage, signage, utilities, and any and all appurtenances thereto, which shall remain intact and under control of the Arizona Department of Transportation, as depicted in the attached Appendix "A" and on the maps and plans of the above referenced project.

All other rights of way, easements and appurtenances thereto, subject to the provisions of Arizona Revised Statutes § 28-7210, shall continue as they existed prior to the disposal of the right of way depicted in Appendix "A".

The abandonment becomes effective upon recordation in the Office of the County Recorder in accordance with Arizona Revised Statutes § 28-7213.

June 19, 2026

RES. NO. 2026-06-A-023
PROJECT: 303L MA 002 H7139 / 303-A(206)N (Phase I)
HIGHWAY: BOB STUMP MEMORIAL PARKWAY
SECTION: I-10 Traffic Interchange (Camelback Rd. - Olive Ave.)
ROUTE NO.: State Route 303L
DISTRICT: Central
COUNTY: Maricopa
DISPOSAL: D-C-112-A

This resolution is considered the conveying document for the right of way to be abandoned; and no further conveyance is legally required.

Pursuant to Arizona Revised Statutes § 28-7046, I recommend that the Arizona State Transportation Board adopt a resolution making this recommendation effective.

Respectfully submitted,

AUDRA MERRICK, P. E., Deputy Director
for Transportation / State Engineer
Arizona Department of Transportation

ARIZONA DEPARTMENT OF TRANSPORTATION
205 South 17th Avenue
R/W Titles Section, MD 612E
Phoenix, Arizona 85007-3212

June 19, 2026

RES. NO. 2026-06-A-023
PROJECT: 303L MA 002 H7139 / 303-A(206)N (Phase I)
HIGHWAY: BOB STUMP MEMORIAL PARKWAY
SECTION: I-10 Traffic Interchange (Camelback Rd. - Olive Ave.)
ROUTE NO.: State Route 303L
DISTRICT: Central
COUNTY: Maricopa
DISPOSAL: D-C-112-A

RESOLUTION OF ABANDONMENT

AUDRA MERRICK, Deputy Director for Transportation and State Engineer of the Arizona Department of Transportation, on June 19, 2026, presented and filed with the Arizona State Transportation Board her written report under Arizona Revised Statutes § 28-7046, recommending the abandonment of certain right of way to the City of Goodyear within the above referenced project.

The right of way to be abandoned is no longer needed for state transportation purposes. The City of Goodyear has agreed to accept jurisdiction, ownership and maintenance responsibilities for the right of way in accordance with that certain Waiver of Four-Year Advance Notice of Abandonment and Pavement Quality Report, dated May 18, 2026, executed pursuant to the provisions of Arizona Revised Statutes § 28-7209.

Accordingly, it is recommended that the State's interest in the right of way be abandoned.

The right of way to be abandoned is delineated on the maps and plans on file in the office of the State Engineer, Project Delivery and Operations Division, Phoenix, Arizona, entitled: "Right of Way Plans of the BOB STUMP MEMORIAL PARKWAY, I-10 Traffic Interchange, Project 303L MA 002 H7139 01R / 303-A(206)N (Phase I)", and is shown in Appendix "A" attached hereto.

WHEREAS said right of way is no longer needed for state transportation purposes; and

June 19, 2026

RES. NO. 2026-06-A-023
PROJECT: 303L MA 002 H7139 / 303-A(206)N (Phase I)
HIGHWAY: BOB STUMP MEMORIAL PARKWAY
SECTION: I-10 Traffic Interchange (Camelback Rd. - Olive Ave.)
ROUTE NO.: State Route 303L
DISTRICT: Central
COUNTY: Maricopa
DISPOSAL: D-C-112-A

WHEREAS the City of Goodyear has agreed to accept jurisdiction, ownership and maintenance responsibilities for the right of way in accordance with that certain Waiver of Four-Year Advance Notice of Abandonment and Pavement Quality Report, dated May 18, 2026, executed pursuant to the provisions of Arizona Revised Statutes § 28-7209; and

WHEREAS for the convenience and safety of the traveling public, it is necessary that within the area of abandonment, the State of Arizona, acting by and through its Department of Transportation, shall retain existing access control and all other currently existing facilities and structures of the State Transportation System, if any; and shall reserve a perpetual easement for ingress, egress and maintenance of said existing facilities and structures, if any, including, but not limited to: said access control, soundwalls, drainage, signage, utilities, and any and all appurtenances thereto, which shall remain intact and under ADOT control, as depicted in the attached Appendix "A" and on said maps and plans; and

WHEREAS this resolution is considered the conveying document for such right of way; and no further conveyance is legally required; and

WHEREAS this Board finds that public safety, necessity and convenience will be served by accepting the Deputy Director's report; therefore, be it

RESOLVED that the recommendation of the Deputy Director is adopted and made part of this resolution; be it further

June 19, 2026

RES. NO. 2026-06-A-023
PROJECT: 303L MA 002 H7139 / 303-A(206)N (Phase I)
HIGHWAY: BOB STUMP MEMORIAL PARKWAY
SECTION: I-10 Traffic Interchange (Camelback Rd. - Olive Ave.)
ROUTE NO.: State Route 303L
DISTRICT: Central
COUNTY: Maricopa
DISPOSAL: D-C-112-A

RESOLVED that the right of way depicted in Appendix "A" is hereby removed from the State Highway System and abandoned to the City of Goodyear, in accordance with that certain Waiver of Four-Year Advance Notice of Abandonment and Pavement Quality Report, dated May 18, 2026, and as provided in Arizona Revised Statutes §§ 28-7207, 28-7209 and 28-7210; be it further

RESOLVED that within the area of abandonment, the State of Arizona, acting by and through its Department of Transportation, hereby retains existing access control and all other currently existing facilities and structures of the State Transportation System, if any; and reserves a perpetual easement for ingress, egress and maintenance of said existing facilities and structures, if any, including, but not limited to: said access control, soundwalls, drainage, signage, utilities, and any and all appurtenances thereto, which shall remain intact and under ADOT control, as depicted in the attached Appendix "A" and on the maps and plans of the above referenced project; be it further

RESOLVED that this abandonment becomes effective upon recordation in the Office of the County Recorder in accordance with Arizona Revised Statutes § 28-7213; and that this resolution is the conveying document for the right of way abandoned herein; and no further conveyance is legally required; be it further

RESOLVED that the Deputy Director provide written notice to the City of Goodyear, evidencing the abandonment of the State's interest.

June 19, 2026

RES. NO. 2026-06-A-023
PROJECT: 303L MA 002 H7139 / 303-A(206)N (Phase I)
HIGHWAY: BOB STUMP MEMORIAL PARKWAY
SECTION: I-10 Traffic Interchange (Camelback Rd. - Olive Ave.)
ROUTE NO.: State Route 303L
DISTRICT: Central
COUNTY: Maricopa
DISPOSAL: D-C-112-A

CERTIFICATION

I, AUDRA MERRICK, as Deputy Director for Transportation and State Engineer of the Arizona Department of Transportation, do hereby certify that the foregoing is a true and correct copy from the minutes of the Arizona State Transportation Board, made in official session on June 19, 2026.

IN WITNESS WHEREOF I have hereunto set my hand and the official seal of the Arizona State Transportation Board on June 19, 2026.

AUDRA MERRICK, P. E., Deputy Director
for Transportation / State Engineer
Arizona Department of Transportation

Seal

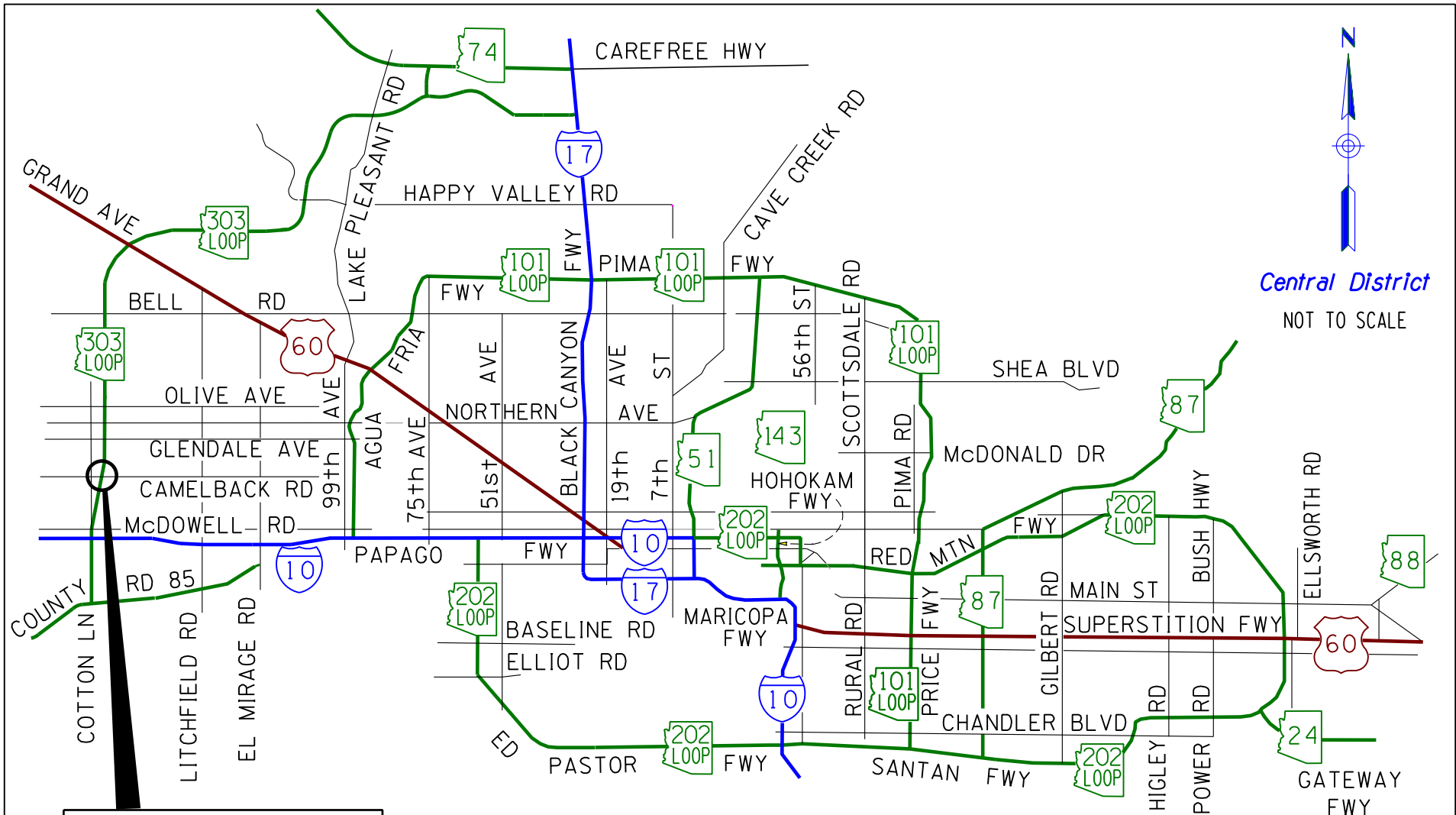

Central District
NOT TO SCALE

Area of Abandonment
See Sheet 2 of 2
for Details

2026-06-A-023
June 19, 2026
Sheet 1 of 2

APPENDIX "A"

303L MA 002 H7139 / 303-A(206)N (Phase 1)
BOB STUMP MEMORIAL PARKWAY
I-10 Traffic Interchange
(Camelback Rd. - Olive Ave.)
Maricopa County

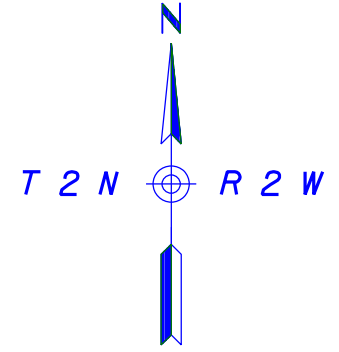

SE⁴ SW⁴

Central District
NOT TO SCALE

STATE ROUTE 303 LOOP

Approx. 1/16 Line
Existing R/W

Future Abandonment Area to City of Glendale

P.O.T. 6+20.00
23.00' Lt. Section Line

P.O.T. 14+11.46
23.00' Lt. Section Line

14 | 13
23 | 24

Section Line
Camelback Rd

P.O.T. 6+20.00
85.00' Rt. Section Line

P.O.T. 11+19.36
75.00' Rt. Section Line

P.O.T. 7+83.83
75.00' Rt. Section Line
85.00' Rt. Section Line

P.O.T. 13+41.95
86.37' Rt. Section Line

P.O.T. 14+11.46
97.12' Rt. Section Line

NE⁴ NW⁴

Existing R/W

ADOT Retains Existing Access Control

Area of Abandonment

303L MA 002 H7139 / 303-A(206)N (Phase 1)
BOB STUMP MEMORIAL PARKWAY
I-10 Traffic Interchange
(Camelback Rd. - Olive Ave.)
Maricopa County

2026-06-A-023
June 19, 2026
Sheet 2 of 2

APPENDIX "A"

**STATE TRANSPORTATION BOARD MEETING
IN PERSON AND
VIRTUAL TELEPHONIC/WEBEX ATTENDANCE**

9:00am, November 21, 2025

Call to Order

Chair Jenn Daniels called the State Transportation Board Meeting to order at 9:02 a.m.

Pledge

The Pledge of Allegiance was led by Floyd Roerich

Roll Call by Board Secretary, Karen Eatherly

A quorum of the State Transportation Board was present. **In attendance (In Person and Via WebEx):** Chair Jenn Daniels, Board Member Jenny Howard, Board Member Sam Elters, and Board Member Jamescita Peshlakai , Vice Chair Ted Maxwell, Alexis Hermosillo were in attendance. There were approximately 70 members of the public on-line and approximately 25 attendees in person.

Opening Remarks

Chair Jenn Daniels

Title VI of the Civil Rights Act

Floyd Roerich, read Title VI of the Civil Rights Act of 1964, as amended. Floyd also reminded individuals to fill out survey cards, with the link shown on the agenda.

Call to the Audience

An opportunity was provided to members of the public to address the State Transportation Board. Members of the public were requested not to exceed a three minute time period for their comments.

ARIZONA STATE TRANSPORTATION BOARD
BOARD MEETING

REPORTER'S TRANSCRIPT OF PROCEEDINGS

VIA WEBEX AND IN PERSON AT:

Town of Wickenburg
155 North Tegner Street
Wickenburg, Arizona 86309

November 21, 2025
9:00 a.m.

REPORTED BY:
TERESA A. WATSON, RMR Perfecta Reporting
Certified Reporter (602) 421-3602
Certificate No. 50876

PREPARED FOR:
ADOT STATE TRANSPORTATION BOARD
(Certified Copy)

CALL TO THE AUDIENCE

In-Person Speakers

- Bobbie Bratcher, Mayor of Wickenburg..... 5
- Nancy Smith, Mayor of Maricopa..... 6
- Tom Drysdale..... 47

Telephonic/WebEx Speakers

- Miranda Sweet, Vice Mayor of Flagstaff..... 9
- Ron Angerame, Resident of Maricopa..... 11
- Stephen Otto, Mayor of Payson..... 13
- Charlie Bell, Payson Town Councilmember..... 16
- Michael McCarty, Gold Canyon Resident..... 17
- Jim Ferris, Payson Town Councilmember..... 20
- Gerald Stevenson..... XX
- Alexander Ritchie, San Carlos Apache Tribe Attorney General.. 23
- Chairman Terry Rambler, San Carlos Apache Tribe..... XX

REPORTER'S TRANSCRIPT OF EXCERPT OF ELECTRONIC

PROCEEDINGS, ARIZONA DEPARTMENT OF TRANSPORTATION, STATE
TRANSPORTATION BOARD MEETING, was reported from electronic media
by TERESA A. WATSON, Registered Merit Reporter and a Certified
Reporter in and for the State of Arizona.

PARTICIPANTS:

Board Members:

- Jenn Daniels, Chair (Absent)
- Ted Maxwell, Vice Chair
- Jenny Howard, Board Member
- Sam Elters, Board Member
- Jamescita Peshlakai, Board Member
- Alexis Hermosillo, Board Member
- Bruce Bracker, Board Member

AGENDA ITEMS

- Item 1 - Director's Report, Jennifer Toth, Director..... 27
- Item 2 - District Engineer's Report..... XX
- Item 3 - Consent Agenda..... 32
- Item 4 - Financial Report, Kristine Ward, Chief Financial Officer..... 32
- Item 5 - Multimodal Planning Division Report, Iqbal Hossain, Deputy Director, Multimodal Planning Division..... 38
- Item 6 - AZ State Match Advantage for Rural Transportation (AZ SMART) Fund Program..... XX
- Item 7 - Priority Planning Advisory Committee (PPAC), Iqbal Hossain, Deputy Director, Multimodal Planning Division..... 41
- Item 8 - State Engineer's Report, Greg Byres, State Engineer..... 43
- Item 9 - Construction Contracts, Greg Byres, State Engineer..... 46
- Item 10 - State Transportation Board Policies 2025, Floyd Roehrich, Jr., Deputy Director - Business Enterprise..... 68
- Item 11 - Suggestions..... 74

1 (Beginning of excerpt.)
 2 CHAIRWOMAN DANIELS: All right. We'll move on to
 3 our call to the audience and want to first ask Mayor Bratcher,
 4 who's -- used to be on this side of the dais, if you would
 5 please join us this morning. Thank you. You're first.

6 MAYOR BRATCHER: Thank you, Chair Daniels, Vice
 7 Chair Maxwell, Board Members, ADOT staff. We are so grateful
 8 for you to be here and choose Wickenburg as one of your
 9 locations I think every year to come and have a meeting, and
 10 it's wonderful to be able to be a part of -- part of that.
 11 Thank you for those who could attend last night. Thank you for
 12 your comments. Very grateful to staff who put that together in
 13 chamber.

14 I just want to say a heart -- heartfelt thank you
 15 for all that you do. Excuse me. I have no idea what that
 16 entails. I have a little idea, but not much. We are very, very
 17 grateful. I know funding is such a big issue for all of what
 18 you do, and that's a hurdle that we are all very concerned
 19 about. Thank you for the progress that you've made so far on
 20 93. We are really excited about what's coming. Thank you for
 21 the study and all that you're involved in as it relates to 60.
 22 We're grateful for that as well. So just all that you do, a
 23 heartfelt thank you.

24 CHAIRWOMAN DANIELS: Thank you.
 25 MAYOR BRATCHER: (Inaudible.)

1 CHAIRWOMAN DANIELS: Thank you, Mayor. Thanks
 2 for your leadership.

3 MR. ROEHRICH: Madam Chair, I apologize. Real
 4 quick, I'm getting reports that some people are being hard to
 5 hear from the board members. Please remember to get close and
 6 speak. Wickenburg has given us the non-lethal mics, so you get
 7 as close as you want. There's nothing wrong with these mics.
 8 But we're hearing that some of them are hard to hear.

9 CHAIRWOMAN DANIELS: Thank you. I'll get closer.
 10 We'd like to invite Mayor Nancy Smith to the
 11 podium. Mayor Smith, welcome.

12 MAYOR SMITH: Thank you. Thank you, members of
 13 the Board, Madam Chair, Vice Chair. Appreciate the opportunity
 14 to speak.

15 I believe I'm becoming a transportation nerd. I
 16 think that's a good thing, because I'm here to talk about
 17 something other than 347 today. I want to -- as my career was
 18 spent significantly at Motorola talking about process
 19 improvement and Six Sigma, I understand the critical importance
 20 of reviewing processes on a regular basis. So I'd like to
 21 remind you of some things that the community of Maricopa went
 22 through in regards to understanding the P2P process, and some of
 23 those things I'd like you to remember as you're reviewing the
 24 P2P process and what changes need to be made.

25 The first is safety. I heard a lot of discussion

1 on the work session about safety. I 100 percent agree.
 2 Consistent value applied, regardless of the type of project, is
 3 really important. Safety is safety. Lives are lives.
 4 Economic vitality. I didn't hear this one
 5 mentioned too much, but it needs to include evaluating the
 6 potential to consider the values of all roads and communities --
 7 all that roads and communities bring. An example is it's not
 8 just about freight trucks moving widgets. It should also apply
 9 to roads connected to cities that supply the workforce that make
 10 the widgets at the locations in which they're traveling. That's
 11 critically important, and if we can't figure out how to include
 12 both elements, then I feel like the measure should be
 13 eliminated, because both aspects of economic development are
 14 critical.

15 Growth. This was huge for the City of Maricopa.
 16 Consideration for areas that are having significant growth. We
 17 shouldn't be waiting for roads to fail when we have housing
 18 permit data that indicates what the growth rate is on the roads,
 19 the communities that are using the roads that we have.

20 Public input. I loved the dialog during the work
 21 session on public input, because better opportunity for public
 22 input to have early on in the process is really critical. I
 23 know one of the board members commented that it isn't well
 24 understood how best to have an impact in each district, and I
 25 100 percent agree with that. We need some work done there.

1 Sources of data is my fifth one. Ensure that
 2 data sources are up to date and inclusive of all important
 3 factors. That was important for us as well.
 4 And then, lastly, the air quality. I didn't hear
 5 anything talked about air quality. When we have congestion on
 6 roads such as 347, it is a big impact to our air quality, and we
 7 know the region around the Phoenix metro area is highly impacted
 8 by air quality.

9 Of course, I can't leave this podium without
 10 mentioning 347. Things are progressing well on the project, and
 11 in order -- I understand we're all going to be fighting for our
 12 money that came from the State, and so in order to keep this
 13 moving forward, let's fight hard to keep this project moving
 14 forward, which ADOT is actually doing a great job on.

15 So thank you very much for the opportunity to
 16 speak.

17 CHAIRWOMAN DANIELS: Thank you, Mayor. Right on
 18 time.

19 I'm showing that Tom Drysdale is wanting to speak
 20 in -- would you like to wait until Agenda Item 9, or would you
 21 like to speak during -- Agenda Item 9. Okay. Thank you.

22 All right. We will move to those on the WebEx
 23 now, if that's amenable, Floyd. Miranda Sweet is our first
 24 WebEx speaker, and Ron Angerame will be on deck.

25 MR. ROEHRICH: So, Brandy, I think Ms. Sweet

9

1 might be the telephone number, and it looks like she's raised
2 her hand. If we could work to help get her unmuted, please.
3 UNIDENTIFIED SPEAKER: She went away.
4 MR. ROEHRICH: Ms. Sweet, are you -- if you're
5 there, please raise your hand.
6 CHAIRWOMAN DANIELS: Can we please coach her on
7 the...
8 VICE MAYOR SWEET: Hello. This is Miranda Sweet.
9 Can you all hear me?
10 CHAIRWOMAN DANIELS: We can.
11 MS. SWEET: Great. Thank you, Chair and members
12 of the Board. I am vice mayor of the City of Flagstaff. I am
13 on the Metroplan board, RTAC board, and on the Mountain Line
14 board, and I am here today to request that you fund the
15 Metroplan's highest priority voted on by our members on the
16 state highway system in the region, US-180 safety improvements.
17 This project will make critical safety improvements on one of
18 our region's highest crash roadways.
19 From 2018 to 2022, ADOT, alongside partners from
20 nine agencies, conducted a corridor master plan study to
21 identify improvements for US-180. This request is to implement
22 the findings of that effort. There are currently no sidewalks
23 leading to the school and no crossings from residential areas to
24 those schools and parks on the other side of the road. In fact,
25 there are no signalized crossing of the road for over three

10

1 miles in this urban and suburban area of Flagstaff. Three miles
2 is too far for any pedestrian to walk out of their way to cross
3 a road. Instead, they do what any of us would do in that -- in
4 those circumstances. They run across the road, trying to split
5 the gap between cars.
6 The city is ready to partner with ADOT to make
7 improvements a reality. We are currently advancing scoping and
8 design through a transportation alternatives program award. We
9 have also set aside money in our capital plan to partner on
10 construction for a total of \$3 million in investment. Metroplan
11 and its partners are asking ADOT to step up to finish
12 implementing the plan for an estimated 5.6 million. We urge you
13 to include the US-180 project in your next update to your five-
14 year capital plan.
15 Thank you, and I hope you all have a great day.
16 CHAIRWOMAN DANIELS: Thank you. Miranda.
17 Ron, you are up, and Charles Bell, a
18 councilmember from the Town of Payson, will be on deck.
19 UNIDENTIFIED SPEAKER: Please raise your hand so
20 I may unmute you.
21 CHAIRWOMAN DANIELS: Is it star three to raise
22 your hand?
23 UNIDENTIFIED SPEAKER: Yes. He should be
24 unmuted.
25 CHAIRWOMAN DANIELS: Ron.

11

1 MR. ROEHRICH: Yeah, he's there. I see his hand
2 raised.
3 UNIDENTIFIED SPEAKER: Yeah. I am unmuting him.
4 UNIDENTIFIED SPEAKER: He should be.
5 UNIDENTIFIED SPEAKER: Mayor (inaudible), you are
6 unmuted.
7 MR. ROEHRICH: No. It's Ron Angerame is the next
8 speaker.
9 UNIDENTIFIED SPEAKER: Oh, I'm sorry. Okay.
10 MR. ROEHRICH: Brandy, Ron Angerame.
11 UNIDENTIFIED SPEAKER: Mr. Angerame, you are
12 unmuted.
13 MR. ANGERAME: Can you hear me now?
14 CHAIRWOMAN DANIELS: Yes.
15 MR. ANGERAME: Oh, great. Thank you, ADOT board,
16 for this opportunity to discuss State Route 347. Firstly, I
17 want to express my gratitude again for including State Route 347
18 in the five-year plan.
19 Additionally, I appreciate your recent decision
20 to consolidate the various 347 projects into one cohesive plan,
21 which has the potential to reduce overall project costs while
22 accelerating the timeline.
23 I recently analyzed the 2024 ADOT accident data,
24 specifically focusing on State Route 347. As Chairperson
25 Daniels has emphasized the importance of data sources, I want to

12

1 clarify that all the data I'll be presenting comes exclusively
2 from ADOT, ensuring its reliability. On a positive note, though
3 it's not really positive news. The data indicates that the
4 number of fatalities and serious injuries has remained roughly
5 the same as in 2023. However, there are areas of concern that
6 need attention, particularly the intersections at Casa Blanca
7 and Mammoth Road, a/k/a Cement Plant Road, require examination.
8 The plan proposes a grade separating the traffic
9 at Mammoth Way to allow free flowing traffic on 347. At
10 Casa Blanca, the plan includes extending turn lanes and adding
11 acceleration and deceleration lanes to alleviate congestion.
12 However, I must note that the number of accidents at Casa Blanca
13 is three times higher than at Cement Plant Road. Most of these
14 accidents are rear-end collisions, and I question how extending
15 turn lanes and adding acceleration and deceleration lanes will
16 effectively address this issue.
17 I would like to understand why Cement Plant is
18 prioritized over Casa Blanca, given that Casa Blanca presents
19 more danger to drivers. Wouldn't it make -- wouldn't it be more
20 effective to consider implementing an overpass or an underpass
21 at Casa Blanca instead?
22 Addressing these issues is not just about
23 improving the traffic flow. It's also about ensuring the safety
24 of the community we serve. As we move forward in planning and
25 budgeting, I urge the Board to prioritize safety and consider

1 how we can enhance the infrastructure at Casa Blanca. As
 2 always, your consideration of these concerns is greatly
 3 appreciated. Thank you for your time.
 4 CHAIRWOMAN DANIELS: Thank you, Ron.
 5 We'll move to Charles Bell, and on deck will be
 6 Mayor Otto.
 7 UNIDENTIFIED SPEAKER: Mr. Bell, if you can raise
 8 your hand, I can look at you on the list and unmute you.
 9 MR. ROEHRICH: Brandy, do you see Mr. Bell on
 10 the --
 11 UNIDENTIFIED SPEAKER: Yes. I've sent him a
 12 request to unmute.
 13 MR. ROEHRICH: Okay.
 14 UNIDENTIFIED SPEAKER: Mr. Bell, if you're using
 15 a phone, you can select star six to unmute.
 16 Madam Chair, you want to go on to Mayor Otto?
 17 He's -- oh, he just lowered his hand. His was up as well.
 18 Maybe go to him and see if Mr. Bell can log back in.
 19 CHAIRWOMAN DANIELS: All right. We will skip
 20 Councilman Bell for the time being, move to Mayor Otto, and
 21 Michael McCarty will be on deck.
 22 UNIDENTIFIED SPEAKER: Mayor Otto, you are
 23 unmuted.
 24 MAYOR OTTO: All right. Chairwoman Daniels,
 25 members of the Arizona Transportation Board, good morning. I'm

1 Stephen Otto, Mayor of Payson. I'm joined by Councilman Jim
 2 Ferris and Councilman Charlie Bell on this feed, so that's why
 3 Charlie couldn't unmute himself.
 4 We're here to talk about Arizona State Highway
 5 260. Thank you for keeping the Lion Springs project in the
 6 queue for construction this cycle. Since you and your board met
 7 here in Payson, the situation on Highway 260 has gotten worse.
 8 Recently, three people were killed in a head-on crash between a
 9 car and an ambulance. Two of the fatalities were
 10 firefighters -- paramedics. Recently, at the intersection of
 11 Chaparral Drive and 260, a Jeep with four young people collided
 12 with a motorist, and the young people suffered life-changing
 13 (inaudible).
 14 I heard at your last work study that freight
 15 movement is one of the priorities in the determination of road
 16 projects. The AZ Highway 377 to AZ Highway 277 to AZ Highway
 17 260 has become a major route for tractor-trailers hauling
 18 freight to and from the East Valley. Due to the rural nature of
 19 Arizona Highway 260, when a crash occurs, no alternate route
 20 exists for a detour. Each crash on AZ Highway 260 stops all
 21 freight traffic up to half a day.
 22 I understand the need for study and design, the
 23 elements to make Highway 260 safer, so I'd like to propose four
 24 elements to achieve that goal. Legislation was written about
 25 2017 establishing safety corridors, and a pilot project was

1 undertaken in freeway-type roads.
 2 I think a safety corridor on Highway 260 from the
 3 turnoff to Willow Springs Lake on Highway 260, Mile Marker 285,
 4 to Highway 87, Mile Marker 250, would greatly improve safety by
 5 cutting down passing and prohibited zones and slow speeds. The
 6 safety corridor would only require signage and the reinstatement
 7 of the legislation. Our State Senator Wendy Rogers has
 8 indicated that she would help us with the legislation portion of
 9 this work.
 10 I also request an ADOT traffic study to be
 11 conducted for a week at the intersection of Chaparral Pines
 12 Drive and Highway 260 during the month of July. The observed
 13 traffic flow would need to include the expected traffic from the
 14 new Juniper Pines development. A second traffic feasibility
 15 study needs to be conducted in Star Valley due to high traffic
 16 volume and no pedestrian crosswalks.
 17 Difficulty accessing 260 from side streets. I've
 18 been told there are no crosswalks for 88 miles for four separate
 19 communities, Star Valley, Forest Lakes, Heber and Overgaard.
 20 The final request and the biggest is an engineering and
 21 construction of a second right turn lane from northbound 87 to
 22 eastbound 260 to help reduce traffic tie-ups through Payson.
 23 Thank you for your time. Please consider our
 24 request. I am Mayor Steve Otto. And I understand we're going
 25 to have a field inspection early December to share our concerns

1 with our state senator, Wendy Rogers, and one of your board
 2 members. Thank you.
 3 CHAIRWOMAN DANIELS: Thank you, Mayor Otto.
 4 UNIDENTIFIED SPEAKER: As long as it doesn't snow
 5 and we can fly.
 6 CHAIRWOMAN DANIELS: Does Councilman Bell still
 7 wish to speak?
 8 MR. BELL: I'm here also. Thank you, Chair and
 9 board members for this opportunity. We certainly appreciate
 10 your attentive understanding by including us in this time frame.
 11 I just want to reiterate what Mayor Otto has
 12 stated, but my real concern is the Town of Payson. I'm going on
 13 11 years here in Payson, Arizona, coming up in March. I've seen
 14 an increase in freight traffic, the large trucks coming through
 15 the town. Also, major backup. This major backup really starts
 16 in the month of June, once school gets out, and really goes
 17 through the month of September. We have individuals that are
 18 traveling in the right lane that are backed up to the casino,
 19 and at times all the way down to (inaudible). What happens
 20 during this time frame is people become antsy, and all of a
 21 sudden, they'll pull out into the left lane as people are
 22 traveling in the right lane, which becomes a hazard for those
 23 individuals that are traveling north on 87.
 24 Also, there's (inaudible) going on to our side
 25 roads, which has increased over the years, and it's kind of

1 hindering those of us who live here in Payson that we have
2 routes to get around the traffic so those individuals that
3 want -- who want to enjoy Rim Country and Mogollon and going up
4 to Heber and Overgaard, so we can get through town and so they
5 can get through town.

6 Again, I would ask for your consideration to
7 monitor the 87 up until the 260, where it turns right, so that
8 we can get an accurate account. I would impress upon you that
9 this monitoring time should be during the months of July, August
10 and September so you can get an accurate count of how many
11 vehicles and trucks that are passing through Payson.

12 Once again, thank you very much for your time and
13 all your energy, and appreciate everything that you do for us.

14 CHAIRWOMAN DANIELS: Thank you, Councilman Bell.
15 Michael McCarty, you are up, with Jim Ferris on
16 deck. Councilman Jim Ferris.

17 UNIDENTIFIED SPEAKER: You are unmuted.

18 MR. MCCARTY: Hello. Can you hear me?

19 CHAIRWOMAN DANIELS: We can.

20 MR. MCCARTY: Thank you. My name is Michael
21 McCarty. I have a residence in Gold Canyon, Arizona. Board
22 Members, thank you for the opportunity to speak directly to each
23 of you today, and thank you for all your efforts regarding the
24 transportation needs in Arizona and particularly Pinal County.

25 My request to speak today is to urge support for

1 the improvements to the intersection of US-60 and Superstition
2 Mountain Drive. As president of the Superstition Mountain Golf
3 and Country Club, Homeowners Association, on Monday,
4 November 10th, I had the opportunity to attend a homeowners
5 association summit in Gold Canyon. This summit was attended by
6 business and community leaders, as well as public officials from
7 the city of Apache Junction and Pinal County. Nearly 7,000
8 homes were represented by the 20 HOAs, adding up to well over
9 10,000 residents in the East Valley.

10 In a survey of the group, transportation ranked
11 as the number one priority in our area. A couple of months ago,
12 this board did approve design funds for improvements to the
13 intersection of US-60 and Superstition Mountain Drive. I'm told
14 by an ADOT representative that this design is planned to be 60
15 percent complete by midyear '26, but not completed until the end
16 of '26. This seems like an incredibly long time frame for
17 design.

18 We've also received an estimate from ADOT of the
19 cost of the work being slightly over \$1.1 million, including the
20 design. But as you know, the design -- 'til the design is
21 complete and the work bid, we really don't have a hard number.
22 Just FYI, a second turn lane was added at Kings Ranch Road, just
23 a mile and a half away, within the past couple of months. So
24 that might serve as a good comp on the cost.

25 I hope that you've seen the executive summary

1 that was forwarded to you yesterday. Due to the strong
2 residential and commercial growth in this area, the need to have
3 a second left turn lane from eastbound US-60 onto northbound
4 Superstition Mountain Drive is critical. For your information,
5 Superstition Mountain Drive already does have two northbound
6 lanes. Additionally increasing the stacking of both left turn
7 lanes would also be critical. The intersection has seen
8 multiple accidents, and recently, a six-car chain reaction
9 accident happened at this intersection.

10 As one heads east on US-60, the freeway ends at
11 Mountain View Drive. It is less than a mile and a half from
12 there to the first stoplight, which is Superstition Mountain
13 Drive. Then within the next three miles, there are three more
14 stoplights at Mountain Brook Drive, Kings Ranch Road and Peralta
15 Trail. These four stoplights, while necessary, do back up
16 traffic, especially since US-60 is used as a main connector to
17 and from metro Phoenix for semi trucks and other commercial
18 vehicles.

19 While I requested to speak about the urgent need
20 to improve the US-60 and Superstition Mountain Drive
21 intersection by adding the second left turn lane, I think the
22 ultimate solution for a traffic situation on US-60 in this area
23 is to complete the Highway 24 extension all the way to US-60,
24 and not just stopping at Ironwood, as it's currently planned.

25 Thank you for your time and attention, and happy

1 Thanksgiving.

2 CHAIRWOMAN DANIELS: Thank you, Michael.
3 Jim Ferris, Councilman Ferris, and on Deck is
4 Gerald Stevenson

5 MR. ROEHRICH: So, Brandy, I think Councilman
6 Ferris is with Mayor Otto.

7 (Speaking simultaneously.)

8 UNIDENTIFIED SPEAKER: He's un- -- I know. They
9 are unmuted.

10 MR. ROEHRICH: Okay.

11 MR. FERRIS: Yes. Can you hear me?

12 CHAIRWOMAN DANIELS: We can.

13 MR. FERRIS: Okay. My name is Jim Ferris. I'm a
14 councilman with Payson, and Chair Daniels and the whole
15 committee, I appreciate the opportunity to address you.

16 Our -- my main concern is with the right turn
17 lane that we would like to have installed here going from north
18 on 87 to east 260. We feel that that -- getting the traffic
19 through town would help reduce a lot of people that try to find
20 a faster way through our neighborhood, residential streets.

21 And the other thing to me I'm concerned about is
22 because of that traffic and the way it flows through Payson,
23 I -- we believe that there's a lot of people that would
24 otherwise stop and maybe do business, spend some time in Payson,
25 but their main goal is just to get through Payson and get out of

1 the traffic jam that's here, because if they leave the road,
 2 it's hard to get back on either 87 or 260.

3 Just like the stress, too, that this traffic
 4 flow, the efficiency of it would help in case of a wildfire,
 5 we'd need to evacuate. It'd be critical to have the -- this
 6 extra lane to get people through Payson.

7 The other thing with a 260 safety zone, I think
 8 that would be very important to get done. It looks like maybe
 9 the Lion Springs project would start in 2027. This safety zone
 10 would also have the effect of doing speed calming as that
 11 project gets initiated. I just -- when, you know, there's --
 12 with the development of this Juniper Pines just east of Payson,
 13 you're looking at a lot of people going in and out of that road
 14 and other roads that have motor homes, their trailers with
 15 off-road vehicles, pull-behind campers, and those vehicles
 16 trying to get out into that traffic, it creates a big problem
 17 and a lot of anxiety for -- for the drivers.

18 So I -- but I just wish that the -- that right
 19 turn lane, especially from 87 to 260, be looked at and
 20 considered, and as Councilman Bell and Mayor Otto said, that the
 21 traffic study, you do that traffic study during the summer
 22 months, and it's going to give you a whole different result than
 23 if they do it in the winter months.

24 So it's -- and, you know, the other thing with
 25 that extra turn lane, too, it may help prevent other commercial

1 vehicle accidents that would have hazardous material or
 2 flammable material on it.

3 So I appreciate your time and your consideration.
 4 Thank you.

5 CHAIRWOMAN DANIELS: Thank you, Councilman
 6 Ferris. And then we'll move to Gerald Stevenson.

7 UNIDENTIFIED SPEAKER: Mr. Stevenson, you're
 8 unmuted.

9 MR. ROEHRICH: Mr. Stevenson, we can't hear you
 10 if you're speaking.

11 It looks like he's unmuted, Brandy, from your
 12 end, right?

13 UNIDENTIFIED SPEAKER: Yes.

14 MR. ROEHRICH: Oh, he just -- he went away.

15 UNIDENTIFIED SPEAKER: I just unmuted him a
 16 second time.

17 MR. ROEHRICH: Mr. Stevenson, we cannot hear you.
 18 If you're on a phone, make sure you're not double muted.
 19 Sometimes people have done that.

20 UNIDENTIFIED SPEAKER: If you are on a phone, you
 21 can select star six and it will unmute you.

22 CHAIRWOMAN DANIELS: Brandy, maybe we'll come
 23 back to Gerald after -- if you can help him offline for a second
 24 with --

25 UNIDENTIFIED SPEAKER: Yes.

1 CHAIRWOMAN DANIELS: -- the connection. Thank
 2 you. We appreciate that.

3 Is there anyone else that we've missed or that
 4 requested to speak?

5 MR. ROEHRICH: So, Madam Chair, the only thing I
 6 remember, you got an email from -- was Mr. Ritchie from the San
 7 Carlos. He said he's going to be here in person, but I don't
 8 see them here, but it does look like he might be online. So I
 9 don't know if he chose at the last minute not to come here. He
 10 did not fill out a request to speak, but if you want to allow
 11 it, he -- it's up to you.

12 CHAIRWOMAN DANIELS: Yeah. Mr. Ritchie -- we did
 13 receive a letter that's part of the record for -- from the
 14 chairman, Chairman Rambler. Mr. Ritchie, would you like to
 15 speak? If so, we can allot three minutes.

16 MR. ROEHRICH: It looks like he did raise his
 17 hand, so if you can unmute him, Brandy, please.

18 UNIDENTIFIED SPEAKER: Mr. Ritchie, you are
 19 unmuted.

20 MR. RITCHIE: Good morning.

21 CHAIRWOMAN DANIELS: Good morning.

22 MR. RITCHIE: Good morning. I also believe
 23 Chairman Rambler is on the phone, somewhere in your list maybe.
 24 I just want to make sure Chairman Rambler's letter was received
 25 November -- dated November 18; is that correct?

1 CHAIRWOMAN DANIELS: Yes, we have received it.

2 MR. RITCHIE: Okay. Madam Chair, members of the
 3 Board, thank you for the opportunity. Chairman Rambler's letter
 4 outlines the issues presented by the tribe. There are hundreds
 5 of folks going in and out of the egresses along US-70, for both
 6 the casino operation, the healthcare operation, the tribe's
 7 government operations.

8 There's been four studies which point to the need
 9 for basic highway improvements. Senator Rogers has been very
 10 helpful by putting together a request two years ago, followed up
 11 by last year's request, and I understand she's submitted another
 12 request through (inaudible) council for this amount.

13 The tribe respectfully requests that this be
 14 included in the five-year capital plan for the State, and the
 15 basis of it is that even though there may be just a relatively
 16 low amount of fatalities and accidents, these have a devastating
 17 high impact amongst members of the tribe and the surrounding
 18 communities.

19 The tribe's request has been supported by mayors
 20 from Safford, Thatcher, Pima, Globe, the Gila County Board of
 21 Supervisors and the Graham County Board of Supervisors, and
 22 respectfully, we wish that the Board considers including this
 23 request.

24 We'd also note there's been some issue about
 25 whether or not to include a traffic light at the -- what's

1 called Apache Gold Casino and Resort. It's a hotel, a gas
2 station and a casino operation and a convention center, plus the
3 rodeo center. That was not included in our request because
4 ADOT, I understand, had issues with planning for it. There's a
5 turnout lane, but they felt that there's no need for a stop
6 sign. We -- a stoplight. We disagree, respectfully.

7 With that, I would like to defer to Chairman
8 Rambler, if he's on the line. Thank you for your time and the
9 opportunity to speak.

10 CHAIRWOMAN DANIELS: Thank you, Alex.

11 We'll move to Chairman Rambler.

12 UNIDENTIFIED SPEAKER: Chairman Rambler, if you
13 can raise your hand.

14 MR. ROEHRICH: If you're on the phone, that would
15 be pushing star three to identify yourself.

16 So, Madam Chair, I don't see anybody raising
17 their hand. Gerald Stevenson --

18 UNIDENTIFIED SPEAKER: Madam --

19 MR. ROEHRICH: -- is still waiting.

20 CHAIRWOMAN DANIELS: Brandy --

21 UNIDENTIFIED SPEAKER: I've sent Mr. Stevenson a
22 request to unmute.

23 CHAIRWOMAN DANIELS: Okay.

24 UNIDENTIFIED SPEAKER: Mr. Stevenson, you are
25 unmuted.

1 CHAIRWOMAN DANIELS: Mr. Stevenson, are you
2 available?

3 Okay. Mr. Stevenson, we'll encourage you to send
4 us an email through the portal, and we'll gladly accept your
5 comments that way, and you'll also get another chance next
6 month. Apologies for the technological challenge.

7 Chairman Rambler, I just want to double-check
8 that we don't have Chairman Rambler.

9 MR. ROEHRICH: I do not see a hand raised.
10 Brandy, you don't see anything, do you?

11 UNIDENTIFIED SPEAKER: No, I do not.

12 CHAIRWOMAN DANIELS: Okay.

13 UNIDENTIFIED SPEAKER: Mr. Stevenson is still
14 unmuted.

15 CHAIRWOMAN DANIELS: Yeah. We've waited --

16 MR. ROEHRICH: Yeah. He's got some particular
17 difficulty, Brandy. I think, as the Chairman said, we're going
18 to just move on.

19 UNIDENTIFIED SPEAKER: Okay.

20 MR. ROEHRICH: He'll have another opportunity in
21 the future.

22 CHAIRWOMAN DANIELS: Thank you for your help
23 today, Brandy. I know it's no easy task. Appreciate it.

24 All right. That concludes our call to the
25 audience. Thank you, everyone.

1 We'll move to Agenda Item 1, our executive
2 director, Jenn Toth.

3 DIRECTOR TOTH: Good morning. Thank you to the
4 Town of Wickenburg for welcoming us. We definitely appreciate
5 your hospitality. So I have a few agency highlights to share
6 today.

7 Next slide, please.

8 So first off, after many years of state service,
9 three members of our ADOT executive team are retiring: Deputy
10 Director and Chief Operating Officer Teresa Welborn will retire
11 in December, and Deputy Director Floyd Roehrich and Kristine
12 Ward will retire in March of next year. So I'm getting --
13 sorry. It is definitely bittersweet to say goodbye. We are
14 excited for their next chapter. Kristine has a big smile every
15 time she comes in the office, but we will definitely miss them
16 and all they do for the agency and the State of Arizona. The
17 fact that they're retiring does give us an opportunity to
18 realign some of our structure within the executive team and
19 improve some efficiencies.

20 So as you can see on the screen, our new org
21 chart, which will become effective on January 3rd, Wayde Webb,
22 who currently serves as deputy director overseeing our Motor
23 Vehicle and Compliance Divisions, will now become the chief
24 operating officer overseeing Financial Management Services,
25 Administrative Services, HR, equal, and Motor Vehicle and

1 Information Technology.

2 Greg is going to move over to serve as our Deputy
3 Director for Business Enterprise over Procurement Services, the
4 Highways magazine, the Transformation Office and the Employee
5 and Business Development Office, as well as working with the
6 State Transportation Board. So it's a great opportunity for him
7 to learn a different part of our agency. Very excited for that
8 opportunity.

9 Stacy Guillen will continue as our Deputy
10 Director of Law and Policy, and will be adding audit and
11 communication and public involvement to her portfolio.

12 Audra Merrick will be promoted to Deputy
13 Director, State Engineer and oversee Multimodal Planning, the
14 project delivery and alternative delivery.

15 And Jeromy Neumann will be promoted to Deputy
16 Director for Enforcement and Compliance. Also, Enterprise
17 Safety and Business Continuity and Emergency Management, our
18 Traffic Operations Center and incident response units.

19 So I really want to thank our current and
20 incoming deputy directors for their dedication to ADOT. We have
21 a lot to look forward to in the upcoming year. I want to say
22 thank you again to Teresa, Kristine and Floyd. Their commitment
23 to public service really sets the standards for everyone, and I
24 personally am very thankful to everything that they've done in
25 helping us with this transition as well.

1 So next, I want to share how honored I was to
2 attend the Gary Knight Memorial Highway dedication ceremony
3 earlier this month. It was a good opportunity to recognize a
4 previous state transport board member, a Yuma City Council
5 member, among many other functions that he served. Before he
6 passed away, he definitely made a tremendous impact through his
7 decades of service to Arizona and his commitment to improving
8 our transportation infrastructure, not just in the Yuma County
9 area, but across the entire state.

10 So on November 6th, signs were unveiled to
11 officially designate a stretch of US-95 in Yuma as the Gary
12 Knight Memorial Highway, and I was really pleased to be a part
13 of that event, and Board Member Bracker as well. Thank you for
14 attending. And I'm happy that his legacy will be permanently
15 connected to US-95, as he really fostered that project itself.

16 So next, big congratulations to ADOT's
17 Communication and Public Involvement Team for taking home four
18 awards at the Phoenix Chapter of the Public Relations Society of
19 America's 2025 Copper Anvil Award. So they were recognized for
20 their great work on Broadway Curve and I-17. This isn't the
21 first award they've won for those two projects. It's been
22 really amazing work that they've done on those projects.

23 Next slide.

24 And earlier this month, the winners of this
25 year's safety message contests were announced. We had great

1 participation. We narrowed those down, and the public cast over
2 3,700 votes to choose the winning messages, which were "Camp in
3 the Woods, Not in the Left Lane," and "Fast and Furious, Try
4 Safe and Courteous," which I thought that was my favorite. I'm
5 a huge Fast and Furious fan. So it's a great way for people to
6 think about safety, and we love seeing their creativity.
7 They -- the people who sent their messages were invited to, as
8 you see there, attend and input it, actually, into the system to
9 go live on our highway DMS signs.

10 So staying with the topic of safety, I want to
11 wrap up with a reminder that we are headed into the busy winter,
12 as we've already seen this week. That means more people are on
13 the road for travel during the holiday season, as well as we
14 have the potential for snow, ice and weather conditions. We
15 even saw hail this week in Phoenix.

16 So every year we share our safety tips with
17 drivers, including, you know, pack a safety kit, including extra
18 drinking water, your phone chargers, flashlights, blanket, and
19 it's also a good idea to plan your travel route. You can visit
20 the AZ511.gov or download the actual app, the 511 app, or dial
21 5-1-1 for updated road weather conditions.

22 And make sure your vehicle is in driving
23 condition for winter conditions. Make sure you've got those
24 windshield and wiper blade fluids. Use snow tires and chains if
25 it's recommended for the snowy and icy roads, and ensure your

1 headlights and taillights and brake lights are visible to
2 everyone. And definitely, the most important thing, please
3 never pass a snowplow. Please slow down. Be patient. You can
4 always find more information on our website, Know Snow. That's
5 K-N-O-W, not N-O.

6 So safe travels, everyone, and a happy
7 Thanksgiving holiday. Thank you.

8 CHAIRWOMAN DANIELS: Thank you, Director Toth.
9 Any comments or questions from the Board for the
10 Director?

11 There was an unofficial safety message contest at
12 my house, in case you wanted to know if I'm raising other
13 transportation nerds, as Nancy called them, and they're very
14 upset that I did not actually submit their entries into the
15 actual contest. I told them they have to wait until I'm off the
16 Board.

17 VICE CHAIR MAXWELL: So what's the best one?

18 CHAIRWOMAN DANIELS: No. I can't. Some of them
19 are unrepeatable, actually.

20 MR. ROEHRICH: I think we get some like that,
21 too, sometimes.

22 DIRECTOR TOTH: Yeah, we do.

23 CHAIRWOMAN DANIELS: Hopefully there's a filter.
24 Thank you, Director Toth, and appreciate that.

25 And congratulations to the individuals who are in

1 new roles. Please know that the Board wants to support you.
2 And for those who are choosing to move on, we, of course, wish
3 you all the best. I hear retirement is really amazing. I may
4 never see it, but I hear it's really, really great.

5 All right. We will move to Item Number 2, but we
6 have no district report today, so we'll move directly to Item 3
7 our consent agenda. Does any member of the board wish to have
8 something removed from the consent agenda?

9 And I failed to mention that Board Member
10 Peshlakai has joined us. And I'm sorry. I just wanted to make
11 sure for people who might just be listening that they know that
12 you're here.

13 Agenda Item 3, any -- anything to pull?

14 Okay. We'll entertain a motion.

15 MR. BRACKER: Move to approve.

16 VICE CHAIR MAXWELL: Second.

17 CHAIRWOMAN DANIELS: We have a motion by Board
18 Member Bracker and a second by Vice Chair Maxwell.

19 All in favor, please say aye.

20 BOARD MEMBERS: Aye.

21 CHAIRWOMAN DANIELS: Any opposed?

22 And Board Member Hermosillo?

23 MS. HERMOSILLO: Aye.

24 CHAIRWOMAN DANIELS: Thank you.

25 All right. Let's move on to Agenda Item 4 and

1 invite Kristine Ward to the podium.

2 MS. WARD: Well, good morning, Board Members. I

3 love traveling to Wickenburg. It's just a beautiful

4 (inaudible).

5 Okay. Where are we? We got it up there? There

6 you go. Thanks so much.

7 All right. I -- the word of the day is all

8 things in moderation. That's what our report is today. I love

9 moderation in this sense, because we've got a nice, stable

10 financial report.

11 Starting off with the Highway User Revenue Fund.

12 Again, within target range. We collected about \$600 million

13 year to date. Remember, we are aiming for a \$1,855,000,000

14 forecast, and so we're right on target for that. Just a titch

15 ahead.

16 If you look into the individual categories on the

17 next slide, and we're looking at October's actuals. This is

18 just for the month of October. These individual categories,

19 there's nothing -- nothing of significance going on here.

20 You'll see we're 1 percent above October of 2025, and just a

21 titch above forecast.

22 Moving on to the Regional Area Road Fund, same

23 story. Nice and moderate. And if I can turn the page

24 correctly, I'll actually get to see the Regional Area Road Fund.

25 1 percent above forecast. \$191 million collected year to date.

1 In terms of an overall forecast, what we're heading for there is

2 about 790 million bucks.

3 Individual categories, nothing significant to

4 report, although you might see a little wacky number on the 50

5 percent in the Other category. First of all, keep in mind the

6 Other category is very, very small, but we had an -- this is

7 where DOR does its audit adjustments and various other things.

8 So that's what you're seeing there is we had an audit adjustment

9 come through.

10 Moving on to the next slide. Where we are in

11 terms of obligation. Chair Daniels, this is that slide, and you

12 weren't here last month, but I would have told you, hey, we

13 couldn't get it until this month. So welcome back. Sure.

14 Here's your slide. We are only a couple -- we're not even two

15 full months into the federal fiscal year, and we've got 10

16 percent of the -- of the program obligated.

17 And last but not least, where we are with our

18 federal aid program. We've got nothing to report there. In

19 terms of debt, the issuance of debt, we'll be coming back to you

20 and talking to you about a debt issuance coming up here in the

21 next three to four months.

22 And I'm hearing myself. And with that, I'm happy

23 to take any questions.

24 MR. ROEHRICH: So, Ms. Peshlakai, you're -- when

25 you logged in, your device is on. You need to mute and turn off

1 the volume, please.

2 CHAIRWOMAN DANIELS: I don't think (inaudible)

3 did it.

4 UNIDENTIFIED SPEAKER: Got it.

5 UNIDENTIFIED SPEAKER: Got it.

6 MS. PESHAKAI: Sorry.

7 CHAIRWOMAN DANIELS: That's okay.

8 MR. ROEHRICH: Thank you.

9 UNIDENTIFIED SPEAKER: No worries.

10 CHAIRWOMAN DANIELS: It's a little hard to see

11 the slides on the screen in front of us, so a lot of us are

12 using that to be able to see.

13 VICE CHAIR MAXWELL: I think I'm the oldest one

14 on the panel. I'm the only one not using it. I don't get it.

15 MR. ROEHRICH: Somebody needs to talk -- oh, I

16 see.

17 CHAIRWOMAN DANIELS: Those are tricky

18 (inaudible).

19 VICE CHAIR MAXWELL: You ready to go?

20 CHAIRWOMAN DANIELS: I actually have one

21 question. Sorry. We got districted.

22 MS. WARD: No worries.

23 CHAIRWOMAN DANIELS: The second-to-last slide,

24 you have a very small orange line that says Adjustments.

25 MS. WARD: Uh-huh.

1 CHAIRWOMAN DANIELS: So you have Planned and then

2 you have Adjustments. The adjustments are based on votes that

3 happen at this board, correct?

4 MS. WARD: Correct. Well, there's one adjustment

5 that happens that's not -- it doesn't come through this board.

6 CHAIRWOMAN DANIELS: Okay.

7 MS. WARD: So when we -- when a project

8 completes, we do a reconciliation process. It's called the

9 final voucher process, and in that process, you might release

10 money back into the program from projects that this board

11 approved some time ago, and those could be projects that were

12 approved -- you know, they were approved in prior years, and

13 many years ago sometimes. So that's what you'll see. And when

14 we do the forecasts for the subsequent program, the five-year

15 program, we build in a component of estimated final voucher

16 dollars coming back into the program.

17 CHAIRWOMAN DANIELS: Okay.

18 MS. WARD: All right.

19 CHAIRWOMAN DANIELS: That's helpful.

20 I have one more. Sorry. I had a constituent

21 reach out to me this week and asked me a specific question about

22 federal funding that I didn't have the answer to, and I thought,

23 oh, good, I have an opportunity on Friday to ask Kristine.

24 If there is a federally awarded project that's

25 not specific to the project but comes in as sort of the bulk of

1 federal funds that exist through our system, but it's not a
2 grant, it's not a job -- a project specific grant is the
3 differential, and the project gets canceled by the
4 jurisdiction -- could be county, could be city -- does that
5 money that was issued federally go back into the big pot, or
6 does it stay within that jurisdiction?

7 MS. WARD: I -- Chair Daniels, probably -- I will
8 preface this with saying I think I probably need a little more
9 detail on --

10 CHAIRWOMAN DANIELS: I actually told them it's so
11 nuanced that they're probably (inaudible).

12 MS. WARD: My first gut reaction to that is if
13 they were, like, a -- like, Congressionally directed spending,
14 if something is directed to a specific project and that project
15 is canceled, that's all that that -- those funds are designated
16 for, and so they wouldn't go back into a pot that we could --

17 CHAIRWOMAN DANIELS: Reallocate.

18 MS. WARD: -- that this board could reallocate.

19 CHAIRWOMAN DANIELS: Got it.

20 MS. WARD: But barring more details on that
21 particular situation --

22 CHAIRWOMAN DANIELS: I'm just going to send them
23 to you, if that's okay.

24 MS. WARD: Go for it. Sometime in April would be
25 good.

1 CHAIRWOMAN DANIELS: Yeah, yeah.

2 VICE CHAIR MAXWELL: Yeah.

3 CHAIRWOMAN DANIELS: There's a do not disturb
4 button that you'll have on.

5 MR. ROEHRICH: Why the hell didn't I think of
6 that? All I need is another meaningful (inaudible).

7 VICE CHAIR MAXWELL: Yeah.

8 CHAIRWOMAN DANIELS: Well, we're now entering the
9 circle back after the holidays time frame, too.

10 MR. ROEHRICH: Yeah. Right.

11 CHAIRWOMAN DANIELS: So you always have that in
12 your back pocket.

13 Thank you, Kristine. Appreciate it.

14 MS. WARD: Thank you.

15 CHAIRWOMAN DANIELS: Any other questions for
16 Kristine? Okay. Thank you.

17 Moving on to Agenda Item 5, and we'll ask Iqbal
18 to come forward for our Multimodal Planning Division report.

19 MR. HOSSAIN: Good morning, Madam Chair and
20 members of the Board. I hope you are doing well this morning.

21 For the record, my name is Iqbal Hossain with the Multimodal
22 Planning Division.

23 Today, I'll share a brief update on several
24 tribal transportation efforts such as safety initiatives,
25 corridor planning and recent community engagement, and there are

1 some coordination meetings I'll share with you.

2 So one major highlight this year is -- in regards
3 to roadway safety is the renewal of the Arizona Safety Circuit
4 Rider Program. This program is a statewide initiative to
5 strengthen roadway safety by supporting tribal governments, our
6 local agencies and other state partners. This program offers
7 hands-on technical assistance and training on roadway safety.
8 One of the most valuable components of this program is helping
9 the tribes prepare the competitive safety grants application.
10 As a matter of fact, currently, we are helping the tribes with
11 such a safety grant application, and the grant's name is Tribal
12 Transportation Program Safety Fund grants.

13 And the best part of all in these programs is all
14 of these services are completely free to our tribal partners,
15 and no cost at all. We simply review the request as we receive,
16 and it's the first come, first services. And so anyone, any
17 tribe that wants support can just send the email to
18 AZSafetyCircuitRider@azdot.gov, and we'll be there to assist,
19 and it's that easy.

20 Next slide.

21 A little update on the State Route 264 Corridor
22 Planning Study. I provided some updates a few months ago on
23 this. This project is located between US-160 in Moenkopi and
24 the eastern boundary of Hopi Tribe. This project looks at
25 safety, mobility, crash data, crash history and long-term needs.

1 And the study started back in November 2024, and since then, we
2 held several information meetings with the community and -- for
3 engagement, and they participated to find the various
4 alternatives on this. It was engaging. There was huge
5 engagement on this process. And this study is on track to be
6 completed next month.

7 Next slide, please. Thank you.

8 So these pictures are from Tohono O'odham
9 Nation's annual El Tour de Rez bicycle -- bicycling event. It
10 took place on October 25th. The event was organized by the
11 Healthy O'odham Promotion Program, and we had the opportunity to
12 support the nation during that event. You see our active
13 transportation coordinator in the picture, there in the biking,
14 and it was a great example of community engagement and active
15 transportation in action.

16 Next one, please.

17 Finally, there are two upcoming tribal
18 coordination meetings. On December 4th, ADOT will hold a full-
19 day partnership meeting with the Hopi Tribe at the Northcentral
20 District in Flagstaff. It is a part -- this is part of our
21 ongoing effort to strengthen our collaboration and technical
22 coordination with our tribal partners.

23 And on January 14th, the 31st Annual Indian
24 Nations & Tribes Legislative Day will be -- take place -- will
25 be taking place at the State Capitol. This event will bring

1 together tribal nations, state leaders and other state partners
2 to discuss priorities, and the registration information is right
3 there listed.

4 With that, this concludes my presentation on the
5 tribal part of transportation updates. I'll be happy to answer
6 any questions you may have.

7 CHAIRWOMAN DANIELS: Any questions from the
8 Board?

9 Okay. Seeing none.

10 Iqbal, don't go anywhere.

11 We do not have any agenda items for 6 today.

12 There were no applications. So we'll move to 7, which is
13 Iqbal's responsibility.

14 Are there any requests from the Board to remove
15 any of the project modifications or new projects from the agenda
16 for discussion?

17 Okay. I think we can take these then in one full
18 motion, if that works for you, Iqbal.

19 MR. HOSSAIN: Sure.

20 CHAIRWOMAN DANIELS: So we have 7A through 7S.
21 Is there a motion?

22 MR. ELTERS: Madam Chair -- sorry. Madam Chair,
23 I move to approve Items 7A through 7F --

24 MS. HOWARD: I'll second.

25 MR. ELTERS: -- as presented.

1 CHAIRWOMAN DANIELS: We have a motion by Board
2 Member Elters and a second by Board Member Howard.

3 All in favor, please say aye.

4 BOARD MEMBERS: Aye.

5 CHAIRWOMAN DANIELS: And I heard you, Board
6 Member Hermosillo, on the phone.

7 Thank you. That motion passes.

8 Were there any opposed, I guess I should ask,
9 just in case?

10 MS. HOWARD: Madam Chair, if I might make just
11 one comment.

12 CHAIRWOMAN DANIELS: Please.

13 MS. HOWARD: 7H, Elota Avenue, that is one of the
14 pavement preservation projects that we moved out of the program
15 when we did add in 260 and 347. So as bid savings come in, we
16 are going to continue to move those three projects that we moved
17 out back into the program. So I just wanted to note that.

18 CHAIRWOMAN DANIELS: That's great. Thank you.
19 And thank you for that update.

20 Any other questions before we let Iqbal escape?

21 VICE CHAIR MAXWELL: Just, Madam Chair, if I
22 could.

23 CHAIRWOMAN DANIELS: Please.

24 VICE CHAIR MAXWELL: I'd just make like to make a
25 little comment. A lot of those projects that were just approved

1 were for some of the local airports, and at the Rural
2 Transportation Summit, we heard from out of the managers of
3 those, some of the small, local airports about the priority of
4 how sometimes they -- their funds are the first ones to be
5 swept. So I appreciate seeing these throughout the -- over the
6 time of the year and get those funds used, because they --
7 they've learned they, too, need to be a little bit more vocal if
8 they want to make sure that the Legislature --

9 UNIDENTIFIED SPEAKER: Correct.

10 VICE CHAIR MAXWELL: -- doesn't touch their
11 money. So we appreciate the opportunity to do that for all the
12 pilots in the -- in the state of Arizona.

13 MR. HOSSAIN: Thank you.

14 CHAIRWOMAN DANIELS: Thank you, Iqbal.

15 MR. HOSSAIN: Perfect.

16 CHAIRWOMAN DANIELS: All right. We'll move on to
17 Agenda Item 8 and invite our state Engineer, Greg, to the
18 podium.

19 MR. BYRES: Good morning, Madam Chair.

20 CHAIRWOMAN DANIELS: Are you wearing all the hats
21 right now, Greg?

22 MR. BYRES: What's that?

23 CHAIRWOMAN DANIELS: You're wearing all the hats,
24 right?

25 MR. BYRES: Yeah. Yeah. So, Madam Chair, Board

1 Members, Item 8, the state engineer's report for November 21,
2 2025. We have 108 projects under construction worth \$2.3
3 billion. Eight projects were finalized in September, worth
4 \$47.9 million. Fiscal year to date, we have 47 projects that
5 have been finalized.

6 And, Madam Chair, we can either go through all
7 the locals or we can -- you have the information if you want to
8 go through that.

9 CHAIRWOMAN DANIELS: It's like you know me now by
10 the end of the term here.

11 Any desire to discuss any of the specific items
12 from the Board?

13 Anything, Greg, that you feel like is of certain
14 item of note that knowing this board now what we might be dying
15 to hear more about?

16 MR. BYRES: The big things that we have that
17 are -- that are coming up, I think, are -- the biggest impacts
18 that we're having is some of the projects that are just getting
19 ready to kick off within the Phoenix region. So we've got a
20 couple of projects on the 303, particularly, that we're looking
21 at that are getting ready to kick off.

22 Also, down in the Tucson region, the Kino, the
23 Country Club, the impacts are starting to hit very big out
24 there. Traffic is still flowing, but it's -- there's a lot that
25 is occurring in that area.

1 And then we could get -- roll into the Ina to
2 Ruthrauff that's almost finished. So we've got completion of
3 one interchange and that project will be completed. So we're --
4 we've a lot going on statewide, but those are probably the
5 biggest ones that we have that are impacting traffic.

6 CHAIRWOMAN DANIELS: I've seen a lot of
7 additional communication recently over some of the future
8 forward, like everybody prepare for, and I think that's helpful.
9 Have you -- Tucson's been heavily impacted?

10 VICE CHAIR MAXWELL: Yeah. I've seen a lot of
11 that, and the communication is going to be the key, especially
12 for the Kino/Country Club. It's -- I mean, realize we're only
13 at two lanes down there on I-10, and every time we talk about
14 the expansion of I-10, I hear it from the folks on the east
15 side. They're saying, wait. You -- we can't stop at 19. We've
16 got to continue going. So the work's greatly appreciated.

17 It is full. There's no doubt. The -- I drive
18 through that section at least twice a week in the mornings,
19 during rush hour, and the continued notifications, any early
20 signage notifications about slowing down, anything you can put
21 down there will help, because as we know, at that time of the
22 morning, people are driving pretty fast to try to get places,
23 and it does happen suddenly, and right when it happens, it
24 also -- you've had to sidestep the roads.

25 So future communications is the important thing

1 we have from a safety standpoint to -- both to the public and in
2 the vicinity of the slowdown. I mean, we heard today about, you
3 know, a six-car collision. It's -- when they happen, they
4 happen big, and then it shuts everything down. So appreciate
5 that picking up, and it's definitely important in that region.

6 MR. BYRES: Will do.

7 CHAIRWOMAN DANIELS: I might just suggest I saw
8 some interesting technology that's being used to notify drivers
9 while they're in process or using apps like Waze and others that
10 they can -- we can notify and send some sort of -- I would
11 imagine our communications team is well-versed on that. They're
12 excellent at what they do, but I just thought I'd flag. Maybe
13 there might --

14 VICE CHAIR MAXWELL: Uh-huh. Uh-huh.

15 CHAIRWOMAN DANIELS: -- be additional technology
16 opportunities. As I was going through the Board's -- the Board
17 policies and looking at some of commitments that we've made as a
18 board through those policies to implement new technologies, it
19 just sort of rose to the top as maybe a new opportunity that we
20 should consider or pursue more in depth.

21 Thank you. Thank you, Greg.

22 Any other questions for Greg on his engineer's
23 report?

24 Okay. We will move to Agenda Item 9, and Greg,
25 if it's okay, I'm going to ask our citizen who wishes to speak

1 come up first to the podium on Agenda Item 9.

2 So at this point, we will invite Tom Drysdale,
3 the president of DBA Construction, who's here in person, and
4 welcome you to the podium, Tom. And a reminder that it's three
5 minutes to speak.

6 MR. DRYSDALE: Wow. Excuse me. Good morning,
7 Madam Chair. As I said earlier, it's going to take me probably
8 more than three minutes, but I'll try to rush through this.

9 Basically, I am the president and founder of DBA
10 Construction, and I'm also the chairman of the board for the
11 Arizona Chapter, Associated General Contractors. So I have a
12 little bit of feeling what you guys probably get every meeting,
13 so I appreciate what you do, and I want to thank you in advance.
14 I'm here today to talk about --

15 CHAIRWOMAN DANIELS: Tom, can I ask you to get
16 just a little closer to that microphone?

17 MR. DRYSDALE: Oh, I'm sorry.

18 CHAIRWOMAN DANIELS: Thank you. Appreciate it.

19 MR. DRYSDALE: I'm here today to talk about US-60
20 project. We bid that job and had an issue, and I kind of wanted
21 to explain it to you, so the quickest way I could do it, I put
22 together a timeline.

23 In 2018, we bid an ADOT job. At that time, we
24 were disqualified as we made error in the NAICS code, and ADOT
25 notified us. We were nonresponsive, and they awarded it to the

1 second bidder.

2 Moving along, in 2019, ADOT issued statewide
3 notice to all prequalified contractors saying that your NAICS
4 code must be accurate and complete and timely to be eligible for
5 award.

6 Move on to 2022. There was a job bid, and there
7 was a NAICS code error. At that time, there was second bidder.
8 No one to protest, and the State did award that job.

9 Now, since then, there's been no updates or
10 guidance on this issue.

11 September 5th, the bids were opened for the US-60
12 job. W.W. Clyde was (inaudible) low, DBA Construction was
13 second, and Granite Construction was third.

14 On October 15th, we received a letter from the
15 state engineer recommending award to Clyde.

16 On October 16th, we received a letter that was
17 sent to FHWA from the director of ADOT that stated the projects
18 that opened before October 3rd should move forward to avoid
19 delays. This project fits in that category.

20 On October 21st, we filed a protest, and on
21 November 18th, the state engineer withdrew the award
22 recommendation.

23 So what I would really like to do is ask the
24 Board -- here's my ask. Two of them. Number one, all of the
25 specifications. If you do that, you award this job to the

1 second bidder. In the examples here -- I have them all here,
2 and I will give them to you -- but since 2018 to 2025, the
3 wording has never changed in your specifications, and the
4 letters that were sent to me show that. The only thing that
5 changed on those pages, in the instructions to bidders was in
6 2018 was page 13, and in page -- 2025 at page 15. I have those
7 for you. I will give those to you.

8 And lastly, I think what we all heard today,
9 passing on jobs is not what the public wants, and I think that
10 we all work with the public. We need to build work, fix roads
11 and continue on.

12 So, Madam Chair, does anybody on the Board have
13 any questions?

14 CHAIRWOMAN DANIELS: Thank you, Tom, for the
15 presentation. I think we'll hold off on any questions for right
16 now, if that is okay with the Board, and we'll come back to
17 questions. It's -- I'm of the opinion we may need to have a
18 sidebar conversation about this that would possibly entail an
19 executive session, so I'm going to hold off right now on any
20 questions.

21 MR. DRYSDALE: Can I give you the information so
22 you can refer to it?

23 CHAIRWOMAN DANIELS: Oh, you mean hand it to us?

24 MR. DRYSDALE: Yeah.

25 CHAIRWOMAN DANIELS: Oh, of course.

1 MR. DRYSDALE: I'm old school.

2 CHAIRWOMAN DANIELS: Yeah, yeah.

3 MR. DRYSDALE: (Inaudible.) There's no mute
4 button on me.

5 CHAIRWOMAN DANIELS: I followed. I followed.
6 Yeah. Thank you.

7 MR. DRYSDALE: I've got them right here.

8 CHAIRWOMAN DANIELS: Appreciate it. Thank you.
9 What is it the judge says? Please approach the
10 bench or something?

11 VICE CHAIR MAXWELL: Yeah.

12 CHAIRWOMAN DANIELS: Thank you.

13 MR. DRYSDALE: Thank you all for your time.

14 CHAIRWOMAN DANIELS: This is not a judge. Yeah.

15 MR. DRYSDALE: I appreciate what you do.

16 CHAIRWOMAN DANIELS: Thank you, Tom. Appreciate
17 that.

18 All right. Greg, we'll invite you back up.

19 MR. BYRES: So, Madam Chair, do you want to go
20 straight to Item 9D and keep on going with this?

21 CHAIRWOMAN DANIELS: I would -- I would like us
22 to go to 9B, but first, because I like efficiency, are there any
23 questions from anyone on the Board on Items 9A, 9C or 9F?

24 UNIDENTIFIED SPEAKER: And 9B.

25 CHAIRWOMAN DANIELS: And 9 --

1 MR. ROEHRICH: And 9B, I think --

2 VICE CHAIR MAXWELL: 9B as well.

3 CHAIRWOMAN DANIELS: I'm going to -- I'm going to
4 come back to those other ones. So those -- 9A, 9B and 9F, those
5 are the ones that are being requested to award.

6 UNIDENTIFIED SPEAKER: And A, B, C and F.

7 VICE CHAIR MAXWELL: C. C's also being requested
8 for award.

9 MR. ROEHRICH: A, B, C and F. 9A, 9B, 9C and F.

10 CHAIRWOMAN DANIELS: I'm skipping B for right
11 now. So 9A, 9C and 9F.

12 VICE CHAIR MAXWELL: Madam Chair, I'll move that
13 we approve as recommended on 9A, which is to reject the bid as a
14 single bidder. 9- --

15 CHAIRWOMAN DANIELS: 9A is to award.

16 MR. ROEHRICH: The amendment -- we did an
17 amendment -- Madam Chair --

18 UNIDENTIFIED SPEAKER: Got it. Yeah.

19 MR. ROEHRICH: Yeah. Okay.

20 CHAIRWOMAN DANIELS: I will say our agenda was a
21 little confusing this month, so --

22 MR. ROEHRICH: Because of the amendment.

23 CHAIRWOMAN DANIELS: Well, not just because of
24 the amendment. There was a couple other things, I think, got
25 moved around, so -- and I can show those to you guys later, but

1 9A is to award, 9C is to award, and 9F is to award.

2 Did I miss any other recommendations to award,
3 besides 9B, which we're holding?

4 UNIDENTIFIED SPEAKER: That's correct.

5 CHAIRWOMAN DANIELS: Okay.

6 VICE CHAIR MAXWELL: I will move to award 9A, 9C
7 and 9E --

8 CHAIRWOMAN DANIELS: 9F.

9 VICE CHAIR MAXWELL: -- as recommended -- 9F as
10 recommended.

11 CHAIRWOMAN DANIELS: Thank you.

12 We have a motion. Is there a second?

13 MR. ELTERS: I'll second it, Madam Chair.

14 CHAIRWOMAN DANIELS: Thank you.

15 We have a motion by Vice Chair Maxwell and a
16 second by Board Member Elters.

17 All in favor, please say aye.

18 BOARD MEMBERS: Aye.

19 CHAIRWOMAN DANIELS: Any opposed?

20 All right. That motion carries. So 9A, C and F
21 are completed.

22 On Agenda Item 9D and 9E, we have a request to
23 reject and a request to postpone. Is there a motion?

24 Did we get that right? We didn't get it right.

25 Okay.

1 MR. ROEHRICH: NO.
 2 CHAIRWOMAN DANIELS: My agenda is wrong. What's
 3 9D?
 4 UNIDENTIFIED SPEAKER: So 9D is to reject all
 5 bids.
 6 CHAIRWOMAN DANIELS: Uh-huh.
 7 UNIDENTIFIED SPEAKER: And that is the --
 8 MR. ROEHRICH: The protest that --
 9 UNIDENTIFIED SPEAKER: -- item that Mr. --
 10 VICE CHAIR MAXWELL: We're holding on that one.
 11 CHAIRWOMAN DANIELS: Oh, okay.
 12 MR. ROEHRICH: Mr. Drysdale.
 13 CHAIRWOMAN DANIELS: Thank you.
 14 UNIDENTIFIED SPEAKER: Yeah.
 15 MR. ROEHRICH: So you action 9A, C and F. If you
 16 go to 9D, Madam --
 17 CHAIRWOMAN DANIELS: I really botched this this
 18 morning.
 19 MR. ROEHRICH: -- award --
 20 CHAIRWOMAN DANIELS: So in my effort to be
 21 efficient, I apparently wasn't. I messed up --
 22 MR. ROEHRICH: (Inaudible) just do them
 23 individually, but I know you like to lump them together.
 24 CHAIRWOMAN DANIELS: I do.
 25 MR. ROEHRICH: So --

1 CHAIRWOMAN DANIELS: Next time just correct me,
 2 Floyd. Okay.
 3 MR. ROEHRICH: We have 9C, which is recommended
 4 to award, and that's the last one to award.
 5 CHAIRWOMAN DANIELS: 9B is the one we haven't
 6 done.
 7 UNIDENTIFIED SPEAKER: Correct.
 8 CHAIRWOMAN DANIELS: So is there a motion on 9B
 9 to award?
 10 MR. ELTERS: Madam Chair, 9B, as in boy, correct?
 11 CHAIRWOMAN DANIELS: Correct.
 12 MR. ELTERS: Madam Chair, I move to award Item 9B
 13 as presented.
 14 CHAIRWOMAN DANIELS: Thank you.
 15 MR. BRACKER: Second.
 16 CHAIRWOMAN DANIELS: We have a motion by Board
 17 Member Elters and a second by Board Member Bracker.
 18 All in favor on Item 9B, please say aye.
 19 BOARD MEMBER: Aye.
 20 CHAIRWOMAN DANIELS: Any opposed?
 21 All right. That motion carries.
 22 Item 9E, to postpone. Is there a motion?
 23 MS. PESHAKAI: Madam Chair, I move that we
 24 postpone Item 9E.
 25 CHAIRWOMAN DANIELS: Thank you.

1 VICE CHAIR MAXWELL: Second with a request.
 2 CHAIRWOMAN DANIELS: Please.
 3 VICE CHAIR MAXWELL: Greg, can you explain -- I
 4 know we only got one bidder.
 5 MR. BYRES: So there's only one bidder on this
 6 project, and there was an issue with the bid. We are currently
 7 going through it. We do not believe it is material, but we need
 8 to vet it out. The time frame didn't allow for us to be able to
 9 get that completed before the board meeting, so we will be
 10 bringing that back next month.
 11 CHAIRWOMAN DANIELS: Thank you.
 12 VICE CHAIR MAXWELL: Could I have a follow-up
 13 question, please, Madam Chair?
 14 CHAIRWOMAN DANIELS: Of course.
 15 VICE CHAIR MAXWELL: So with a single bidder --
 16 MR. BYRES: Yes.
 17 VICE CHAIR MAXWELL: -- we're spending time and
 18 delaying this. Why don't we just re-advertise and see if we can
 19 get multiple bidders and worry about it from that point?
 20 MR. BYRES: That's one of the options that we're
 21 looking at, sir.
 22 VICE CHAIR MAXWELL: Any thought from the Board
 23 on why we wouldn't want to do that versus continue to spend
 24 time, or do you think we'll have this solved by next month?
 25 MR. BYRES: We will.

1 VICE CHAIR MAXWELL: Okay.
 2 MR. ELTERS: Madam Chair, Board Member Maxwell,
 3 given that this is in District 6, I did reach out to the
 4 department prior to the board meeting today. Greg provided a
 5 good explanation. My sense would be allow the department to
 6 complete the process. That is one of the options. It's not
 7 always guaranteed that you would get a better bid if you to --
 8 were to rebid it. If this is a good bid, I would recommend
 9 we'll let them complete the process.
 10 VICE CHAIR MAXWELL: Madam Chair, I'll gladly
 11 defer to Member Elters on this one as it's his district.
 12 CHAIRWOMAN DANIELS: All right. We have a motion
 13 by Board Member Elters and a second by Board Member -- or Vice
 14 Chair Maxwell.
 15 All in favor on 9E to postpone, please say aye.
 16 BOARD MEMBERS: Aye.
 17 CHAIRWOMAN DANIELS: Thank you. Any opposition?
 18 All right. That motion carries as well.
 19 Okay. Now we can get to 9D. Thank you.
 20 MR. BYRES: Thank you, Madam Chair.
 21 CHAIRWOMAN DANIELS: Don't leave any hanging
 22 Chads here. 9D, please present.
 23 MR. BYRES: So Item 9D is a City of Apache
 24 Junction project. This is on Old West Highway. The low bid was
 25 \$2,818,889. The State's estimate was \$4,363,049, a difference

1 of \$1,544,160, or 35.4 percent.

2 Part of the rationale that was given for the

3 lower price was smaller crew sizes, as well as location

4 materials were justifiable in the cost.

5 We brought this project to the Board last month

6 for a -- with a recommendation for postponement. It was

7 postponed. The rationale we gave was with the bidders --

8 because there was an issue with the bid, specifically one of the

9 DBE items, we needed to be able to contact all bidders. There's

10 a time frame that's allotted for doing such. That time frame

11 had not been completed yet. We brought it forth for

12 postponement, and the Board postponed.

13 Since that time, we received a letter that

14 brought forth a -- an issue with the bid, so therefore -- which

15 was just commented on prior -- we have gone through and spoken

16 with the City of Apache Junction on this specific bid. In those

17 conversations, we made it aware that they -- there was an issue

18 with the bid and that there was a -- one of the -- the second

19 contractor had come through protesting the bid. So, therefore,

20 we needed to be able to act.

21 One of the recommendations that was made, that I

22 made to the city was that we reject all bids, take and

23 re-advertise this project as soon as possible to try and keep

24 this project online and get it completed as it's -- as was

25 necessary. So the City of Apache Junction agreed with that, and

1 so with that, we come before the Board with a recommendation to

2 reject all bids.

3 CHAIRWOMAN DANIELS: Okay. Questions from the

4 board for Greg? Oh, sorry. Questions from the Board for Greg?

5 This kind of stuff makes me really uncomfortable,

6 if I'm just being totally transparent, because of the legalities

7 that are associated with it. So you're putting something in

8 front of us that we haven't been able to discuss in an executive

9 session or in some sort of -- to get legal guidance and advice,

10 and I'm very, very uncomfortable with sort of being put in that

11 position. So just to be very clear on that.

12 Any other comments from the Board on...

13 MR. BRACKER: Being new on the board, are we

14 allowed to go into an executive session to talk about a specific

15 issue like this?

16 CHAIRWOMAN DANIELS: We are agendized to do that,

17 but do we have our attorney here?

18 MR. ROEHRICH: Madam Chair, she is online. We

19 can go in there and get her on one of your all's cell phones, if

20 you have it, and you can converse with her that way. I may have

21 to figure out how to get Ms. Hermosillo on that.

22 CHAIRWOMAN DANIELS: We can call -- I mean, I can

23 call her on my --

24 UNIDENTIFIED SPEAKER: Yeah. We can have two

25 phones on.

1 UNIDENTIFIED SPEAKER: Somebody can call her on a

2 cell phone.

3 MR. ROEHRICH: Yeah.

4 CHAIRWOMAN DANIELS: Yeah. Given sort of the

5 sensitivity of this, is there a motion to recess and move into

6 executive session?

7 MR. BRACKER: Madam Chair, I'd like to make a

8 motion that we recess into an executive session to talk about

9 Item 9D.

10 MS. HOWARD: I'll second.

11 MR. ELTERS: I'll second.

12 CHAIRWOMAN DANIELS: All right. We have a motion

13 by --

14 VICE CHAIR MAXWELL: Madam Chair?

15 CHAIRWOMAN DANIELS: Yes.

16 VICE CHAIR MAXWELL: Just one question. I agree.

17 I think we need to go into executive session and get a legal

18 opinion. My question is: Are there any questions we want to

19 ask before we go into executive session versus coming out and

20 finding out there was something else that we wanted?

21 We heard -- I mean, we did hear from

22 Mr. Drysdale, his belief, that he's asking us to follow the

23 process and procedures that we've used in the past. I think

24 Mr. Byres has outlined that there's been some other times where

25 we've maybe not done -- we've made the decision to not handle

1 this with the same situation. So I guess -- I guess my answer

2 is you've heard what Mr. Drysdale's concerns are. What would

3 you want us to know before we go into an executive session?

4 Then I'd also like to give Mr. Drysdale one last opportunity

5 to -- if there's anything he's concerned about that we may

6 discuss in executive session.

7 CHAIRWOMAN DANIELS: Okay.

8 VICE CHAIR MAXWELL: Again, I'm not an elected

9 official, so --

10 CHAIRWOMAN DANIELS: No.

11 VICE CHAIR MAXWELL: -- I'll leave it to those

12 who use executive sessions a little bit more (inaudible).

13 CHAIRWOMAN DANIELS: We're all equals here on

14 this board, to be clear. And I do want to state that we have

15 received this document from Mr. Drysdale, and it will become

16 part of the public record. So just to be clear. I know the

17 public hasn't had a chance to see it yet, but now that it's been

18 submitted.

19 Greg, anything that the public needs to be aware

20 of as we move into executive session?

21 MR. BYRES: So the protest that's before us right

22 now is based on -- that the NISC (sic) codes that were given in

23 the bid were the wrong codes. However, the work that was to be

24 performed was correct. So the codes just needed to be adjusted.

25 Since 2022, we have done that more than once.

1 That has basically become our standard, and the reason for it is
2 we actually went through and had a -- basically, a PDCA with the
3 construction community, because this was happening very
4 regularly, and we were having to reject bids. So we went
5 through this. We came up with -- back in '22, there was a -- an
6 agreement with AGC that, in fact, we would take and this would
7 be -- become a nonmaterial item, as long as the work that was
8 identified was in their bid. So as such, we could adjust the
9 codes if it was the wrong code.

10 In this particular case, all of those codes were
11 for construct -- for concrete, and the concrete was called out
12 in their bid. So, therefore, we could make those adjustments.
13 So we did so, and protest came through. Like I said, this has
14 been a standard since 2022 that we have been utilizing. So --

15 CHAIRWOMAN DANIELS: And it's codified?

16 MR. BYRES: Correct. So --

17 VICE CHAIR MAXWELL: For the public's knowledge,
18 you said it was with. AGC, so the Arizona General Contractors
19 Association, made that agreement.

20 MR. BYRES: That is correct.

21 VICE CHAIR MAXWELL: And codified it?

22 MR. BYRES: Yes. That -- no. There -- it has
23 not been codified. It is our standard policy -- or I should say
24 our standard work --

25 VICE CHAIR MAXWELL: Okay.

1 MR. BYRES: -- that we have been utilizing since
2 2022. So that's what's going on.

3 The reason for my recommendation in to Apache
4 Junction is with the protest as well as the communiques that
5 came from the low bidder, this was obviously going to become a
6 major issue. As such, we were figuring that this was probably
7 going to go to litigation. If it did, this project for Apache
8 Junction was going to get basically pushed back for an extended
9 period of time.

10 So as per -- and I'm going to read this off -- as
11 per Section 103.01 of the Arizona Department of Transportation
12 Standard Specifications For Road and Bridge Construction,
13 there's a statement that reads: The right is reserved to reject
14 any and all proposals, to waive technicalities, or to advertise
15 for new proposals if, in the judgment of the department, the
16 best interest of the department will be promoted thereby.

17 That's included in the betting -- bidding
18 specifications. As such, we -- that is the rationale that we're
19 using to let's reject bids. Let's get this project going so
20 that it can actually be built.

21 CHAIRWOMAN DANIELS: Okay. Vice Chair, are you
22 satisfied for the moment?

23 VICE CHAIR MAXWELL: Yes, Madam Chair. If you --
24 I guess I'd have a question, a follow-up question. Just because
25 Mr. Drysdale made the effort to come out here, I -- we held off

1 on questions at that time. My only follow-up question to be --
2 now that he's heard a further conversation, if there's anything
3 he'd like to add to the comments he made to us --

4 CHAIRWOMAN DANIELS: Before we go into executive
5 session.

6 VICE CHAIR MAXWELL: -- before we go into
7 executive session.

8 CHAIRWOMAN DANIELS: Great. I appreciate that
9 very much. Thank you, Greg.

10 Mr. Drysdale, if you wouldn't mind coming
11 forward. And if I were to summarize Vice Chair Maxwell's
12 question, is there anything else you would like us to know
13 before we go into an executive session?

14 MR. DRYSDALE: There is. We all agree I was --
15 mentioned that I belong to the Arizona Association of General
16 Contractors. However, I want it to be said there's been no
17 updates to the plans, the documents, the bidders. I think
18 keeping ADOT -- you can't have people's opinions come in.
19 That's why those facts are there. That's why in 2019, every
20 prequalified contractor was aware of the NAICS codes, because
21 there was problems.

22 In 2022, it wasn't material, because there was no
23 second bidder. So I have here, and I would like to give to you,
24 Madam Chairman, all the letters I referred to, and I would just
25 like you to look at them, it won't take long, and follow the

1 history.

2 CHAIRWOMAN DANIELS: If you hand those to us,
3 they -- I mean, the law (inaudible) they're probably all public
4 record. I just want you to know that anything you hand us
5 becomes part of the public record.

6 MR. DRYSDALE: Absolutely.

7 CHAIRWOMAN DANIELS: Okay. Perfect.

8 MR. DRYSDALE: Ironically, the gentleman that
9 signed the letter in 2018 is sitting behind me, and the other
10 one is sitting here.

11 CHAIRWOMAN DANIELS: I figured they're all part
12 of a public record anyway. I just wanted to make the statement.
13 I -- there's that disclaimer on the bottom of all public persons'
14 emails now, and I just wanted to make sure you knew. Thank you.
15 Appreciate that.

16 MR. DRYSDALE: I do appreciate your time looking
17 into this. Thank you.

18 CHAIRWOMAN DANIELS: Thank you. Appreciate you.
19 All right. We had a motion from Board Member
20 Bracker and a second by Board Member Elters to go into executive
21 session. We have not yet voted on that.

22 All in favor, please say aye.

23 BOARD MEMBERS: Aye.

24 CHAIRWOMAN DANIELS: Mayor Hermosillo, I think
25 you said aye.

1 MS. HERMOSILLO: Yes. I said aye.
 2 CHAIRWOMAN DANIELS: Thank you. Appreciate it.
 3 All right. Any opposed?
 4 Thank you. We will recess this meeting and
 5 reconvene in executive session.
 6 (Executive session.)
 7 CHAIRWOMAN DANIELS: All right. Is there a
 8 motion to reconvene our meeting?
 9 MR. BRACKER: Madam Chair, I move we leave the
 10 executive session and move into regular session.
 11 MR. ELTERS: Second.
 12 CHAIRWOMAN DANIELS: We have a motion and a
 13 second. All in favor, please say aye.
 14 BOARD MEMBERS: Aye.
 15 CHAIRWOMAN DANIELS: Any opposed?
 16 All right. We are back in our regular meeting.
 17 MR. BRACKER: Madam Chair.
 18 CHAIRWOMAN DANIELS: Yes.
 19 VICE CHAIR MAXWELL: I'd like to move that we
 20 postpone Item 9D.
 21 CHAIRWOMAN DANIELS: Thank you.
 22 We have a motion. Is there a second?
 23 MS. HOWARD: I'll second.
 24 MR. ELTERS: Madam Chair, I second.
 25 CHAIRWOMAN DANIELS: Okay. And I actually should

1 add a request as well that would be part of this motion. We
 2 have been given guidance from our code that allows us to make a
 3 request, and I'll read this directly. It says: The
 4 Transportation Board may hear arguments concerning the protest
 5 or at its discretion, may direct the state engineer to hold a
 6 hearing or other appropriate procedure to evaluate the protest.
 7 If the matter is referred to the state engineer --
 8 MS. KUNZMAN: Madam Chair.
 9 CHAIRWOMAN DANIELS: Yes.
 10 MS. KUNZMAN: We are not able to hear.
 11 UNIDENTIFIED SPEAKER: Oh, your microphone might
 12 not be on.
 13 UNIDENTIFIED SPEAKER: Is it your microphone?
 14 CHAIRWOMAN DANIELS: That's unfortunate, or
 15 fortunate. Thank you, Michelle. I appreciate you highlighting
 16 that for me.
 17 I'm going to read a statement from the code that
 18 gives the Board the authority to direct the state engineer to
 19 hold a hearing. It says: The Transportation Board may hear
 20 arguments concerning the protest or at its discretion, may
 21 direct the state engineer to hold a hearing or other appropriate
 22 procedure to evaluate the protest. If the matter is referred to
 23 the state engineer, the state engineer's recommendation will be
 24 made to the Board within 30 days. The Transportation Board will
 25 make the final decision as to award or the rejection of bids.

1 So that's directly from the code. So as our
 2 motion -- as part of our motion to postpone, and the second, I
 3 do request that the Board also concur with the referral of the
 4 matter to the state engineer to hold a hearing and to report
 5 back to the Board within 30 days, which would be at our next
 6 regular board meeting.
 7 VICE CHAIR MAXWELL: Mr. Barnes (sic), I know you
 8 came up. I was just going to ask if we need to amend my motion
 9 or if we need to/want to take that in two separate motions.
 10 MR. BYRES: It would probably be best in two
 11 separate, because it's actually two different items.
 12 VICE CHAIR MAXWELL: Okay. Then, Madam Chair,
 13 I'd request we further discuss and then call the vote on the
 14 postponement of Item 9D.
 15 CHAIRWOMAN DANIELS: I think we need to do it all
 16 in one since it's part of the same, and my reason being is that
 17 it's not agendized as a separate item. So if we could amend
 18 the --
 19 MR. ROEHRICH: The only -- Madam Chair, what I
 20 would amend is, yeah, amend the amendment, because he first said
 21 postpone. So postpone and direct the state engineer to hold a
 22 hearing on 9 -- Item 9D and bring it back in January.
 23 CHAIRWOMAN DANIELS: Correct.
 24 MR. ROEHRICH: That's the motion.
 25 VICE CHAIR MAXWELL: Then, Madam Chair, in that

1 case, I amend my amendment to direct the state engineer to hold
 2 a hearing regarding the protest and other appropriate procedures
 3 to evaluate the protest.
 4 MR. ELTERS: Madam Chair, I amend my second to
 5 that motion.
 6 CHAIRWOMAN DANIELS: Thank you.
 7 So we have a motion by Vice Chair Maxwell and a
 8 second by Board Member Elters.
 9 All in favor, please say aye.
 10 BOARD MEMBER: Aye.
 11 CHAIRWOMAN DANIELS: Any opposed?
 12 That motion carries. Thank you.
 13 MR. BYRES: Thank you.
 14 CHAIRWOMAN DANIELS: Appreciate everyone's
 15 support as we worked through that. That concludes Agenda
 16 Item 9, and we move to Agenda Item 10, and that is our State
 17 Transportation Board policies.
 18 Floyd, are you presenting on that?
 19 MR. ROEHRICH: So -- yes, Madam Chair. So at the
 20 special meeting we had little over a week ago, we got additional
 21 comments at that meeting, which we have incorporated into the
 22 draft. There are a couple of things, I don't know if you want
 23 to go through this page by page, quick to look at that, but I do
 24 have two items or a couple of things. I know that Board Member
 25 Maxwell talked about developing a mission statement. I don't

1 know if you had any thought more on how to discuss that or add
2 that, if you wanted to continue that. And then, again, if you
3 wanted to go quick, page by page, and look at these, or did you
4 just want to have time to digest these individually and then
5 comment to me so I can bring them back in December? I'll leave
6 it up to your discretion.

7 CHAIRWOMAN DANIELS: There's quite a few edits in
8 there. I don't think going page by page would actually be very
9 efficient, but everyone can see everyone else's edits as part of
10 that, and it also is part of the public record. So if the
11 public wishes to weigh in, that's available to them as well,
12 including our edits.

13 Any other questions for Floyd?

14 So the process, Floyd, is you'll bring these back
15 in December. Just remind us of when we will -- final vote's
16 February?

17 MR. ROEHRICH: The final vote is -- we can make
18 it the last item on -- or the second -- yeah, the last item on
19 the agenda, right after the change, if you want, in December,
20 but our preference would be to approve them in December, but
21 these are the Board's policies. You -- you don't want to do it,
22 you know, I'm not going to force you to do it.

23 CHAIRWOMAN DANIELS: December it is.

24 MR. BRACKER: Madam Chair?

25 CHAIRWOMAN DANIELS: Yes.

1 MR. BRACKER: Floyd, you're also working on
2 language for dark sky?

3 MR. ROEHRICH: That is in there. We added that.
4 If you look on...

5 CHAIRWOMAN DANIELS: It's in there. You might to
6 look at it and just make sure that it follows the intent of what
7 you brought up at our last meeting. I did feel like it might
8 need a tweak.

9 MR. BRACKER: Thank you.

10 MS. HOWARD: Madam Chair.

11 MR. ROEHRICH: I don't remember (inaudible).

12 MS. HOWARD: So we can continue to comment until
13 the next meeting.

14 MR. ROEHRICH: Well, I would like to hold
15 comments maybe by, let's say, the 15th so we can finalize it, do
16 all the formatting. I know there's a lot of formatting issues
17 that need to be done. So if we can have all the comments,
18 because we meet on -- I think it's the 19th. So maybe the week
19 before. So the 12th. If we have all the comments by the 12th,
20 we'll take that -- the rest of that time to finish it up, and
21 then we will get you a clean copy and bring it to the meeting on
22 the 19th.

23 MS. HOWARD: Thank you.

24 VICE CHAIR MAXWELL: And, Madam Chair, and what
25 I'd ask, if we do get any public feedback for any of those

1 (inaudible) transportation walks that want to have feedback to
2 our policies and procedures, if we do get that, if you could
3 pass that on to us, obviously, in advance as well so we know
4 what else they're considering. Because as we all make changes,
5 I think we just need to be aware, and we know probably -- start
6 looking at the 10th, maybe -- at some point, Floyd, basically,
7 maybe cut off...

8 CHAIRWOMAN DANIELS: There are a couple decision
9 points, actually, for the Board, as it -- like, we've
10 immortalized in policy the structure for AZ SMART grants. I'm
11 not sure we want to have that level of language in case -- you
12 know, because it's so dependent upon the Legislature. There's
13 some -- a few things like that that everybody really does need
14 to weigh in on with Floyd by the 12th.

15 There were a couple other questions I think you
16 had outlined, Director Toth, things where we should be more
17 broad rather than being so specific.

18 MR. ROEHRICH: Correct. And, like, certain
19 requests for comment (inaudible) like I-11 to the policies, and
20 that's really too specific to add a route to that, but we are
21 adding language related to international commerce routes, things
22 like that support the same intended purpose.

23 And the other comment I was going to make is if
24 you look in there, you have a section in there about the HELP
25 loan program, which is -- which is a program that the

1 Legislature previously had funded that allowed acceleration of
2 projects and they got paid back. There's no money in that. The
3 Legislature has swept all the money, and it's sitting there.
4 The comment was made, let's remove those from the policies if
5 the program is not viable, and if they ever fund in the future,
6 we obviously have the mechanism to bring it in.

7 VICE CHAIR MAXWELL: Yeah. Agreed.

8 CHAIRWOMAN DANIELS: Yes, and I felt -- I felt
9 similarly about AZ SMART, right?

10 VICE CHAIR MAXWELL: Uh-huh. Right.

11 CHAIRWOMAN DANIELS: So, like, perhaps there is
12 an addendum type.

13 VICE CHAIR MAXWELL: Yeah.

14 CHAIRWOMAN DANIELS: If these programs are in
15 existence, here's the policies that exist with them.

16 VICE CHAIR MAXWELL: Right.

17 CHAIRWOMAN DANIELS: If they're not in existence,
18 this addendum is basically put on the shelf, and...

19 VICE CHAIR MAXWELL: Yeah. That's --

20 MR. ROEHRICH: But we still have money in AZ
21 SMART. I would like to keep things --

22 CHAIRWOMAN DANIELS: And I know we do right now.

23 MR. ROEHRICH: Right.

24 CHAIRWOMAN DANIELS: But we can always refer to
25 an addendum for programs that are in effect.

73

1 VICE CHAIR MAXWELL: And honest -- honestly, I
2 think, Madam Chair, that's the best way to do that. If we have
3 legislative programs that come and go, funding comes and goes, I
4 think we put them in the addendum, and we may put a comment in
5 our policies that we will refer -- that refers to that addendum
6 and how we handle the legislative initiatives. It's -- the
7 Legislature is always going to play with it. They're always
8 going to give us projects, and it's good. I want to see fiscal
9 investment by the Legislature into the specific project, but
10 those always create challenges. I think we could take it out of
11 our official board policies and somehow put it -- capture it in
12 the document, but as an addendum that's easier for us to move in
13 and out of as the funds are available.

14 CHAIRWOMAN DANIELS: In theory, policies should
15 be evergreen, I think, is the thought process, so...

16 VICE CHAIR MAXWELL: That's why --

17 CHAIRWOMAN DANIELS: Yeah.

18 VICE CHAIR MAXWELL: -- if we're going to include
19 anything that addresses any temporary programs, I think we do it
20 as an addendum, because the policy shouldn't -- we shouldn't
21 have to go in and change the policies all the time because the
22 Legislature changes stuff.

23 CHAIRWOMAN DANIELS: Uh-huh. Yeah.

24 MR. ROEHRICH: But to the point, HELP is not a
25 temporary program. It's there. It's just not funded. So

74

1 there's no way -- there's no mechanism to use it.

2 CHAIRWOMAN DANIELS: It would go to the addendum.

3 UNIDENTIFIED SPEAKER: Yeah.

4 VICE CHAIR MAXWELL: To me, that sounds like
5 the -- there's always a regional transportation authority over
6 Pima, but if we don't reauthorize the plan and the funding,
7 there's no purpose to it. So --

8 UNIDENTIFIED SPEAKER: Yeah.

9 VICE CHAIR MAXWELL: -- it's -- we can discuss
10 that, but I would -- I think --

11 CHAIRWOMAN DANIELS: Food for thought.

12 VICE CHAIR MAXWELL: Director, do you have an
13 opinion? I saw you kind of ready (inaudible)?

14 DIRECTOR TOTH: Well, I was going to suggest that
15 we can put those into ADOT policies versus the Board policies
16 when legislative appropriations like that occur. So that -- AZ
17 SMART, HELP, any of those --

18 CHAIRWOMAN DANIELS: Uh-huh.

19 DIRECTOR TOTH: -- situations.

20 VICE CHAIR MAXWELL: I like that plan.

21 CHAIRWOMAN DANIELS: I do, too.

22 VICE CHAIR MAXWELL: I like that plan.

23 CHAIRWOMAN DANIELS: Okay. Sounds good. Clear
24 as mud.

25 All right. That moves us to Agenda Item 11. Any

75

1 suggestions from the Board on future agenda items?
2 All right. Seeing none.
3 Thank you all. Have a very, very happy
4 Thanksgiving, and we will see you next month. Board -- meeting
5 adjourned.
6 (Meeting adjourned.)

76

1 STATE OF ARIZONA)
2) ss.
3 COUNTY OF MARICOPA)

4 BE IT KNOWN that the foregoing proceedings were reported by
5 me, TERESA A. WATSON, Registered Merit Reporter, Certified
6 Reporter, Certificate No. 50876, State of Arizona, from an
7 electronic recording and were reduced to written form under my
8 direction; that the foregoing 75 pages constitute a true and
9 accurate transcript of said electronic recording, all done to
10 the best of my skill and ability.

11 I FURTHER CERTIFY that I am in no way related to any of the
12 parties hereto, nor am I in any way interested in the outcome
13 hereof.

14 DATED at Phoenix, Arizona, this 7th day of June 2026.

15
16
17 /s/ Teresa A. Watson

18 TERESA A. WATSON, RMR
19 Certified Reporter
20 Certificate No. 50876

21
22
23
24
25

Adjournment

Chair Jenn Daniels adjourned the State Transportation Board Meeting on November 21, 2025.

Meeting adjourned at 11:01a.m. PST.

Not Available for Signature

Jenn Dainels, Chair
State Transportation Board

Not Available for Signature

Jennifer Toth, Director
Arizona Department of Transportation

Cumulative AZ SMART Fund Report

Funding Category	ADOT	Muni < 10K	Muni 10K+	County < 100K	County 100K+	Total
Statute	ARS §28-339 F.5 DT6000 738	ARS §28-339 F.4 DT6010 734	ARS §28-339 F.3 DT6015 735	ARS §28-339 F.2 DT6020 737	ARS §28-339 F.1 DT6025 736	
Revenue						
Legislative Appropriations	\$12,500,000	\$12,500,000	\$12,500,000	\$12,500,000	\$12,500,000	\$62,500,000
Interest Earnings	\$1,700,121	\$1,648,914	\$1,600,649	\$1,676,176	\$1,628,235	\$8,254,095
Total Revenues	\$14,200,121	\$14,148,914	\$14,100,649	\$14,176,176	\$14,128,235	\$70,754,095
Approvals						
Grant Development		\$4,600		\$50,000		\$54,600
Match Awards	\$5,371,724	\$31,212	\$17,305,153	\$3,346,000	\$4,602,642	\$30,656,731
Design & Engineering	\$3,750,000	\$11,439,078	\$9,463,707	\$6,260,283	\$6,670,000	\$37,583,068
1% Program Administration	\$100,000					\$100,000
Match Released	(1,250,000)	0	(6,402,008)	(46,000)	0	(7,698,008)
Design Recovered	0	(807,500)	(1,546,772)	(1,204,452)	0	(3,558,724)
Net Approvals	\$7,971,724	\$10,667,390	\$18,820,080	\$8,405,831	\$11,272,642	\$57,137,667
Redistribution						
Net Redistributions/Adjustments ¹	(3,067,609)	(485,429)	5,991,108	(2,585,618)	147,547	0
Current Available for Award	\$3,160,788	\$2,996,095	\$1,271,677	\$3,184,728	\$3,003,141	\$13,616,428
Current Requests						
Items for June STB approval	\$0	\$0	\$0	\$0	\$0	\$0
Current Available After Approval	\$3,160,788	\$2,996,095	\$1,271,677	\$3,184,728	\$3,003,141	\$13,616,428
Pending Requests						
Grant Development		\$15,200		\$0		\$15,200
Match Awards	\$0	\$0	\$3,964,767	\$0	\$0	\$3,964,767
Design & Other Eng Svcs (DOES)	\$2,500,000	\$1,305,209	\$0	\$0	\$0	\$3,805,209
Total Pending Requests	\$2,500,000	\$1,320,409	\$3,964,767	\$0	\$0	\$7,785,176
After Approval of Pending Requests	\$660,788	\$1,675,686	-\$2,693,090	\$3,184,728	\$3,003,141	\$5,831,252

Notes:

¹Includes all redistributions approved by the Board plus interest earned in January and July but received in the month following Board approval.

PPAC - PROJECT MODIFICATIONS - DISCUSSION AND POSSIBLE ACTION

*ITEM:8a **Route & MP:** 17 @ MP 297.0
 Project Name: MCGUIREVILLE REST AREA
 Type of Work: REHABILITATE REST AREA
 County: Yavapai
 District: Northcentral
 Schedule: FY 2023
 Project: F042501C TIP#: 100240
 Project Manager: Robert Wheeler
 Program Amount: \$4,374,000
New Program Amount: \$1,000
 Requested Action: Cancel Construction Project.

3. Form Date / 5. Form By:

5/26/2026

Laura Thames

4. Project Manager / Presenter:

Robert Wheeler @ Phoenix, AZ 85007

1655 W Jackson St -

6. Project Name:

MCGUIREVILLE REST AREA

7. Type of Work:

REHABILITATE REST AREA

8. CPSID: SP10 9. District: Northcentral 10. Route: 17 11. County: Yavapai 12. Beg MP: 297.0 13. TRACS #: F042501C 14. Len (Mi.): 0.0 15. Fed Id #: NHPP017-B(238)T

16. Program Budget: \$4,374 17. Program Item #: 100240

18. Current Approved Program Budget: \$4,374 18a. (+/-) Program Budget Request: (\$4,373) 18b Total Program Budget After Request: \$1

CURRENTLY APPROVED:

19. BUDGET ITEMS:

Table with 4 columns: Item #, Amount, Description, Comments. Row 1: 100240, \$5,900, ., . Row 2: 72323, (\$1,526), CONTINGENCY, (\$1,525,633)

CHANGE / REQUEST:

19A. BUDGET ITEMS:

Table with 4 columns: Item #, Amount, Description, Comments. Row 1: 72327, (\$4,373), ., (\$4,373,408)

CURRENT SCHEDULE:

21. CURRENT FISCAL YEAR: 23
22. CURRENT BID READY:
23. CURRENT ADV DATE: 3/17/2023

CHANGE REQUEST NEW SCHEDULE:

21A. REQUEST FISCAL YEAR:
22A. REQUEST BID READY:
23A. REQUEST ADV DATE:

20. JPA #s: SIGNED: NO ADV: NO

CHANGE IN: 24a. PROJECT NAME: NO 24b. TYPE OF WORK: NO 24c. SCOPE: NO 24d. CURRENT STAGE: NOT APPLICABLE

24e. ENVIRONMENTAL CLEARANCE: NO 24f. MATERIALS MEMO COMP: NO
24g. U&RR CLEARANCE: NO 24h. C&S CLEARANCE: NO
24i. R/W CLEARANCE: NO 24j. CUSTOMIZED SCHEDULE: NO
24k. SCOPING DOCUMENT: NO

25. DESCRIPTION OF REQUEST

Cancel Construction Project.

26. JUSTIFICATION OF REQUEST

All bids on this project were rejected. Subsequent discussion led to the decision to do the building renewal work using State building renewal funds.

27. CONCERNS OF REQUEST

28. OTHER ALTERNATIVES CONSIDERED

REQUESTED ACTIONS:

CHANGE IN BUDGET

APPROVED / RECOMMENDED ACTIONS:

REQUEST APPROVED
SUBJECT TO PPAC APPROVAL - 6/3/2026

PRB APPROVED

PPAC - PROJECT MODIFICATIONS - DISCUSSION AND POSSIBLE ACTION

*ITEM:8b **Route & MP:** 17 @ MP 297.0
 Project Name: MCGUIREVILLE REST AREA
 Type of Work: REHABILITATE REST AREA
 County: Yavapai
 District: Northcentral
 Schedule: FY 2023
 Project: F042501D TIP#: 100240
 Project Manager: Robert Wheeler
 Program Amount: \$600,000
New Program Amount: \$539,000
 Requested Action: Cancel Project.

3. Form Date / 5. Form By:

5/26/2026

Laura Thames

4. Project Manager / Presenter:

Robert Wheeler @ Phoenix, AZ 85007

1655 W Jackson St -

6. Project Name:

MCGUIREVILLE REST AREA

7. Type of Work:

REHABILITATE REST AREA

8. CPSID:	9. District:	10. Route:	11. County:	12. Beg MP:	13. TRACS #:	14. Len (Mi.):	15. Fed Id #:
SP10	Northcentral	17	Yavapai	297.0	F042501D	0.0	NHPP017-B(238)T

16. Program Budget: \$600

17. Program Item #: 100240

18. Current Approved Program Budget:

\$600

18a. (+/-) Program Budget Request:

(\$61)

18b Total Program Budget After Request:

\$539

CURRENTLY APPROVED:

19. BUDGET ITEMS:

Item #	Amount	Description	Comments
100240.	\$600	.	.

CURRENT SCHEDULE:

21. CURRENT FISCAL YEAR: 23

22. CURRENT BID READY:

23. CURRENT ADV DATE: 3/17/2023

20. JPA #'s: SIGNED: NO ADV: NO

CHANGE / REQUEST:

19A. BUDGET ITEMS:

Item #	Amount	Description	Comments
72327	(\$61)	.	(\$61,289)

CHANGE REQUEST NEW SCHEDULE:

21A. REQUEST FISCAL YEAR:

22A. REQUEST BID READY:

23A. REQUEST ADV DATE:

CHANGE IN:	24a. PROJECT NAME: NO	24b. TYPE OF WORK: NO	24c. SCOPE: NO	24d. CURRENT STAGE: NOT APPLICABLE
24e. ENVIRONMENTAL CLEARANCE:	NO	24f. MATERIALS MEMO COMP:	NO	
24g. U&RR CLEARANCE:	NO	24h. C&S CLEARANCE:	NO	
24i. R/W CLEARANCE:	NO	24j. CUSTOMIZED SCHEDULE:	NO	
24k. SCOPING DOCUMENT:	NO			

25. DESCRIPTION OF REQUEST

Cancel Project.

26. JUSTIFICATION OF REQUEST

Construction project was performed using other funding source. Therefore, the design project can be closed and the remaining balance can be released.

27. CONCERNS OF REQUEST

28. OTHER ALTERNATIVES CONSIDERED

REQUESTED ACTIONS:

CHANGE IN BUDGET

APPROVED / RECOMMENDED ACTIONS:

REQUEST APPROVED
 SUBJECT TO PPAC APPROVAL - 6/3/2026

PRB APPROVED

PPAC - NEW PROJECTS - DISCUSSION AND POSSIBLE ACTION

*ITEM :8c

Route & MP:	
Project Name:	TA Program FY26
Type of Work:	Administration
County:	
District:	
Schedule:	
Project:	MTA2601X_
Project Manager:	Angela Estrada
Program Amount:	\$0
New Program Amount:	\$255,000
Requested Action:	Establish Project.

3. Form Date / 5. Form By:
5/11/2026
Angela Estrada

4. Project Manager / Presenter:
Angela Estrada @ 480.662.1145
1611 W JACKSON ST, 3, 310B - 4210 MPD PLANNING TEAM

6. Project Name:
TA Program FY26

7. Type of Work:
Administration

8. CPSID: 9. District: 10. Route: 11. County: 12. Beg MP: 13. TRACS #: 14. Len (Mi.): 15. Fed Id #:
MTA2601X_ ?

16. Program Budget: \$0

17. Program Item #:

18. Current Approved Program Budget:
\$0

18a. (+/-) Program Budget Request:
\$255

18b Total Program Budget After Request:
\$255

CURRENTLY APPROVED:

19. BUDGET ITEMS:

CHANGE / REQUEST:

19A. BUDGET ITEMS:

Table with 4 columns: Item #, Amount, Description, Comments. Row 1: 71626, \$255, Federal 94.3pct State 5.7pct, \$255,000

CURRENT SCHEDULE:

21. CURRENT FISCAL YEAR:
22. CURRENT BID READY:
23. CURRENT ADV DATE:

CHANGE REQUEST NEW SCHEDULE:

21A. REQUEST FISCAL YEAR:
22A. REQUEST BID READY:
23A. REQUEST ADV DATE:

20. JPA #'s: SIGNED: NO ADV: NO

CHANGE IN: 24a. PROJECT NAME: NO 24b. TYPE OF WORK: NO 24c. SCOPE: NO 24d. CURRENT STAGE: NOT APPLICABLE

24e. ENVIRONMENTAL CLEARANCE: NOT APPLICABLE 24f. MATERIALS MEMO COMP: NOT APPLICABLE
24g. U&RR CLEARANCE: NOT APPLICABLE 24h. C&S CLEARANCE: NOT APPLICABLE
24i. R/W CLEARANCE: NOT APPLICABLE 24j. CUSTOMIZED SCHEDULE: NOT APPLICABLE
24k. SCOPING DOCUMENT: NOT APPLICABLE

25. DESCRIPTION OF REQUEST

Establish Project.

26. JUSTIFICATION OF REQUEST

This project will be used by staff to administer the TA Program.

27. CONCERNS OF REQUEST

28. OTHER ALTERNATIVES CONSIDERED

REQUESTED ACTIONS:

CHANGE IN BUDGET

APPROVED / RECOMMENDED ACTIONS:

REQUEST APPROVED
SUBJECT TO PPAC APPROVAL - 6/3/2026

PRB APPROVED

PPAC - NEW PROJECTS - DISCUSSION AND POSSIBLE ACTION

*ITEM:8d **Route & MP:**
 Project Name: TA Program FY26
 Type of Work: Administration
 County:
 District:
 Schedule:
 Project: MTA2602X
 Project Manager: Angela Estrada
 Program Amount: \$0
 New Program Amount: \$381,000
 Requested Action: Establish Project.

3. Form Date / 5. Form By:
5/7/2026
Angela Estrada

4. Project Manager / Presenter:
Angela Estrada @ 480.662.1145
1611 W JACKSON ST, 3, 310B - 4210 MPD PLANNING TEAM

6. Project Name:
TA Program FY26

7. Type of Work:
Administration

8. CPSID: 9. District: 10. Route: 11. County: 12. Beg MP: 13. TRACS #: 14. Len (Mi.): 15. Fed Id #:
MTA2602X ?

16. Program Budget: \$0

17. Program Item #:

18. Current Approved Program Budget:
\$0

18a. (+/-) Program Budget Request:
\$381

18b Total Program Budget After Request:
\$381

CURRENTLY APPROVED:

19. BUDGET ITEMS:

CHANGE / REQUEST:

19A. BUDGET ITEMS:

Table with 4 columns: Item #, Amount, Description, Comments. Row 1: 71626, \$381, Federal 94.3pct State 5.7pct, \$381,455

CURRENT SCHEDULE:

21. CURRENT FISCAL YEAR:
22. CURRENT BID READY:
23. CURRENT ADV DATE:

CHANGE REQUEST NEW SCHEDULE:

21A. REQUEST FISCAL YEAR:
22A. REQUEST BID READY:
23A. REQUEST ADV DATE:

20. JPA #'s: SIGNED: NO ADV: NO

CHANGE IN: 24a. PROJECT NAME: NO 24b. TYPE OF WORK: NO 24c. SCOPE: NO 24d. CURRENT STAGE: NOT APPLICABLE

24e. ENVIRONMENTAL CLEARANCE: NOT APPLICABLE 24f. MATERIALS MEMO COMP: NOT APPLICABLE
24g. U&RR CLEARANCE: NOT APPLICABLE 24h. C&S CLEARANCE: NOT APPLICABLE
24i. R/W CLEARANCE: NOT APPLICABLE 24j. CUSTOMIZED SCHEDULE: NOT APPLICABLE
24k. SCOPING DOCUMENT: NOT APPLICABLE

25. DESCRIPTION OF REQUEST

Establish Project.

26. JUSTIFICATION OF REQUEST

This project will be used to administer the TA Program by consultants.

27. CONCERNS OF REQUEST

28. OTHER ALTERNATIVES CONSIDERED

REQUESTED ACTIONS:

CHANGE IN BUDGET

APPROVED / RECOMMENDED ACTIONS:

REQUEST APPROVED
SUBJECT TO PPAC APPROVAL - 6/3/2026

PRB APPROVED

PPAC - NEW PROJECTS - DISCUSSION AND POSSIBLE ACTION

*ITEM:8e

Route & MP:

Project Name: Complete Streets Design Guidelines

Type of Work: Update Design Guidelines

County:

District:

Schedule: FY 20 2026

Project: P227001P

Project Manager: Thor Anderson

Program Amount: \$0

New Program Amount: \$483,000

Requested Action: Establish Project.

3. Form Date / 5. Form By:
5/7/2026
Thor Anderson

4. Project Manager / Presenter:
Thor Anderson @ (602) 712-4574
1611 W JACKSON ST, , 310B - 4210 MPD PLANNING TEAM

6. Project Name:
Complete Streets Design Guidelines

7. Type of Work:
Update Design Guidelines

8. CPSID: 9. District: 10. Route: 11. County: 12. Beg MP: 13. TRACS #: 14. Len (Mi.): 15. Fed Id #:
- P227001P ? MPD-A(005)

16. Program Budget: \$0

17. Program Item #:

18. Current Approved Program Budget:
\$0

18a. (+/-) Program Budget Request:
\$483

18b Total Program Budget After Request:
\$483

CURRENTLY APPROVED:

CHANGE / REQUEST:

19. BUDGET ITEMS:

19A. BUDGET ITEMS:

Table with 4 columns: Item #, Amount, Description, Comments. Row 1: 72926, \$483, ., \$483,068

CURRENT SCHEDULE:

CHANGE REQUESTNEW SCHEDULE:

21. CURRENT FISCAL YEAR: 2026
22. CURRENT BID READY: TBD
23. CURRENT ADV DATE: TBD

21A. REQUEST FISCAL YEAR:
22A. REQUEST BID READY:
23A. REQUEST ADV DATE:

20. JPA #'s: SIGNED: NO ADV: NO

CHANGE IN: 24a. PROJECT NAME: NO 24b. TYPE OF WORK: NO 24c. SCOPE: NO 24d. CURRENT STAGE: NOT APPLICABLE

24e. ENVIRONMENTAL CLEARANCE: NO 24f. MATERIALS MEMO COMP: NO
24g. U&RR CLEARANCE: NO 24h. C&S CLEARANCE: NO
24i. R/W CLEARANCE: NO 24j. CUSTOMIZED SCHEDULE: NO
24k. SCOPING DOCUMENT: NO

25. DESCRIPTION OF REQUEST

Establish Project.

26. JUSTIFICATION OF REQUEST

This project will update ADOT's Complete Streets design guidelines since the current guidelines are outdated. This effort will incorporate the latest AASHTO design guidance, complete streets and LPA partnership practices.

27. CONCERNS OF REQUEST

28. OTHER ALTERNATIVES CONSIDERED

REQUESTED ACTIONS:

ESTABLISH A NEW PROJECT

APPROVED / RECOMMENDED ACTIONS:

REQUEST APPROVED
SUBJECT TO PPAC APPROVAL - 6/3/2026

PRB APPROVED

PPAC - NEW PROJECTS - DISCUSSION AND POSSIBLE ACTION

*ITEM: 8f

Route & MP: 85 @ MP 118.1
Project Name: SR 85 PIMA AND STREET
Type of Work: INTERSECTION IMPROVEMENTS
County: Maricopa
District: Southwest
Schedule: FY 2026
Project: F0950 TIP#: .
Project Manager: Skye Gentile Bush
Program Amount: \$0
New Program Amount: \$550,000
Requested Action: Establish New Project.

3. Form Date / 5. Form By:
5/27/2026
Skye Gentile Bush

4. Project Manager / Presenter:
Skye Gentile Bush @ (602) 568-6782
205 S 17th Ave, 2nd Floor - 4983 PROJECT MANAGEMENT

6. Project Name:
SR 85 PIMA AND STREET

7. Type of Work:
INTERSECTION IMPROVEMENTS

8. CPSID: 9. District: 10. Route: 11. County: 12. Beg MP: 13. TRACS #: 14. Len (Mi.): 15. Fed Id #:
HI1R Southwest 85 Maricopa 118.1 F0950 ? 0.4

16. Program Budget: \$0

17. Program Item #: .

18. Current Approved Program Budget:
\$0

18a. (+/-) Program Budget Request:
\$550

18b Total Program Budget After Request:
\$550

CURRENTLY APPROVED:

CHANGE / REQUEST:

19. BUDGET ITEMS:

19A. BUDGET ITEMS:

Table with 4 columns: Item #, Amount, Description, Comments. Row 1: 49926, \$550, RARF Funding, RARF Funding

CURRENT SCHEDULE:

21. CURRENT FISCAL YEAR: 26
22. CURRENT BID READY:
23. CURRENT ADV DATE:

CHANGE REQUESTNEW SCHEDULE:

21A. REQUEST FISCAL YEAR: FY26
22A. REQUEST BID READY:
23A. REQUEST ADV DATE:

20. JPA #'s: SIGNED: NO ADV: NO [checked] PROJECT FUNDING VERIFIED BY PM

CHANGE IN: 24a. PROJECT NAME: NO 24b. TYPE OF WORK: NO 24c. SCOPE: NO 24d. CURRENT STAGE: STAGE I
24e. ENVIRONMENTAL CLEARANCE: NO 24f. MATERIALS MEMO COMP: NO
24g. U&RR CLEARANCE: NO 24h. C&S CLEARANCE: NO
24i. R/W CLEARANCE: NO 24j. CUSTOMIZED SCHEDULE: NO
24k. SCOPING DOCUMENT: NO

25. DESCRIPTION OF REQUEST

Establish New Project.

26. JUSTIFICATION OF REQUEST

This project will improve the intersection at SR 85 and Pima Street by geometric, operational, and access-management enhancements.

Contingent upon MAG Regional Council approval in May 2026. MAG ID number is MAG-20-RTP-704. A TIP number will be assigned following approval.

Staff:\$118k
ICAP:\$32k
Consultant:\$400k

27. CONCERNS OF REQUEST

28. OTHER ALTERNATIVES CONSIDERED

REQUESTED ACTIONS:

ESTABLISH A NEW PROJECT

APPROVED / RECOMMENDED ACTIONS:

REQUEST APPROVED
SUBJECT TO PPAC APPROVAL - 6/3/2026

PRB APPROVED

PPAC - NEW PROJECTS - DISCUSSION AND POSSIBLE ACTION

*ITEM:8g **Route & MP:** 96 @ MP 0.0
Project Name: SAN LUIS BORDER WAIT TIME
Type of Work: Install Vehicle Wait Time Sensors
County: Yuma
District: Southwest
Schedule: FY 2026
Project: M7309 TIP#: .
Project Manager: Chris Moore
Program Amount: \$0
New Program Amount: \$250,000
Requested Action: Establish New Project.

3. Form Date / 5. Form By:
5/26/2026
Chris Moore

4. Project Manager / Presenter:
Chris Moore @ (757) 469-6679
205 S 17TH AVE, - 4983 PROJECT MANAGEMENT

6. Project Name:
SAN LUIS BORDER WAIT TIME

7. Type of Work:
Install Vehicle Wait Time Sensors

8. CPSID: CU1R 9. District: Southwest 10. Route: 96 11. County: Yuma 12. Beg MP: 0.0 13. TRACS #: M7309 ? 14. Len (Mi.): 0.5 15. Fed Id #:

16. Program Budget: \$0

17. Program Item #: .

18. Current Approved Program Budget: \$0

18a. (+/-) Program Budget Request: \$250

18b Total Program Budget After Request: \$250

CURRENTLY APPROVED:

CHANGE / REQUEST:

19. BUDGET ITEMS:

19A. BUDGET ITEMS:

Table with 4 columns: Item #, Amount, Description, Comments. Row 1: 79926, \$250, .

CURRENT SCHEDULE:

CHANGE REQUESTNEW SCHEDULE:

21. CURRENT FISCAL YEAR: 26
22. CURRENT BID READY:
23. CURRENT ADV DATE: TBD

21A. REQUEST FISCAL YEAR:
22A. REQUEST BID READY:
23A. REQUEST ADV DATE:

20. JPA #'s: 25-00111170-I SIGNED: YES ADV: NO

CHANGE IN: 24a. PROJECT NAME: NO 24b. TYPE OF WORK: NO 24c. SCOPE: NO 24d. CURRENT STAGE: NOT APPLICABLE

24e. ENVIRONMENTAL CLEARANCE: NOT APPLICABLE
24g. U&RR CLEARANCE: NOT APPLICABLE
24i. R/W CLEARANCE: NOT APPLICABLE
24k. SCOPING DOCUMENT: NOT APPLICABLE

24f. MATERIALS MEMO COMP: NOT APPLICABLE
24h. C&S CLEARANCE: NOT APPLICABLE
24j. CUSTOMIZED SCHEDULE: NOT APPLICABLE

25. DESCRIPTION OF REQUEST

Establish New Project.

26. JUSTIFICATION OF REQUEST

This project will provide funding with an IGA to the Greater Yuma Port Authority for them to contract with a vendor to implement measurement of border wait times at the San Luis Port of Entry.

27. CONCERNS OF REQUEST

28. OTHER ALTERNATIVES CONSIDERED

REQUESTED ACTIONS:

ESTABLISH A NEW PROJECT

APPROVED / RECOMMENDED ACTIONS:

REQUEST APPROVED
SUBJECT TO PPAC APPROVAL - 6/3/2026

PRB APPROVED

PPAC - NEW PROJECTS - DISCUSSION AND POSSIBLE ACTION

* ITEM: 8h

Route & MP:	92 @ MP 329.4
Project Name:	HEREFORD RD - PALOMINAS RD
Type of Work:	REPLACE FENCE
County:	Cochise
District:	Southeast
Schedule:	
Project:	F079301C TIP#: 104959
Project Manager:	Chinwe Iwuchukwu
Program Amount:	\$0
New Program Amount:	\$2,910,000
Requested Action:	Establish Construction Project.

PPAC - NEW PROJECTS - DISCUSSION AND POSSIBLE ACTION

*ITEM:8i **Route & MP:** 10 @ MP 166.0
Project Name: KOLI RD TI
Type of Work: GRIC CONSTRUCT ACCESS IMPROVEMENTS
County: Maricopa
District: Central
Schedule: FY 2026
Project: F070101R TIP#: 7787
Project Manager: Trent Kelso
Program Amount: \$0
New Program Amount: \$30,446,000
Requested Action: Establish Right of Way Subphase.

3. Form Date / 5. Form By:

5/26/2026

Trent Kelso

4. Project Manager / Presenter:

Trent Kelso @ (602) 723-8313

205 S 17TH AVE, 295., 614E - 4983 PROJECT MANAGEMENT

6. Project Name:

KOLI RD TI

7. Type of Work:

GRIC CONSTRUCT ACCESS IMPROVEMENTS

8. CPSID:	9. District:	10. Route:	11. County:	12. Beg MP:	13. TRACS #:	14. Len (Mi.):	15. Fed Id #:
EA10	Central	10	Maricopa	166.0	F070101R ?	0.0	RARF

16. Program Budget: \$0 **17. Program Item #:** 7787

18. Current Approved Program Budget:	18a. (+/-) Program Budget Request:	18b Total Program Budget After Request:
\$0	\$30,446	\$30,446

CURRENTLY APPROVED:

19. BUDGET ITEMS:

CHANGE / REQUEST:

19A. BUDGET ITEMS:

Item #	Amount	Description	Comments
49926	\$30,446		Koli Rd ROW - RARF

CURRENT SCHEDULE:

21. CURRENT FISCAL YEAR: 26
22. CURRENT BID READY: TBD
23. CURRENT ADV DATE: TBD

CHANGE REQUESTNEW SCHEDULE:

21A. REQUEST FISCAL YEAR:
22A. REQUEST BID READY:
23A. REQUEST ADV DATE:

20. JPA #'s: **SIGNED:** NO **ADV:** NO

CHANGE IN: **24a. PROJECT NAME:** NO **24b. TYPE OF WORK:** NO **24c. SCOPE:** NO **24d. CURRENT STAGE:** NOT APPLICABLE

24e. ENVIRONMENTAL CLEARANCE:	YES	24f. MATERIALS MEMO COMP:	NO
24g. U&RR CLEARANCE:	NO	24h. C&S CLEARANCE:	NO
24i. R/W CLEARANCE:	NO	24j. CUSTOMIZED SCHEDULE:	NO
24k. SCOPING DOCUMENT:	YES		

25. DESCRIPTION OF REQUEST

Establish Right of Way Subphase.

26. JUSTIFICATION OF REQUEST

The project team is ready to move forward with the acquisition of the ROW for the new Koli Road interchange on I-10. The request includes ICAP.

Action approved at MAG Regional Council in December 2025.

27. CONCERNS OF REQUEST

28. OTHER ALTERNATIVES CONSIDERED

REQUESTED ACTIONS:

CHANGE IN BUDGET

APPROVED / RECOMMENDED ACTIONS:

REQUEST APPROVED
 SUBJECT TO PPAC APPROVAL - 6/3/2026

PRB APPROVED

PPAC - AIRPORT PROJECTS - DISCUSSION AND POSSIBLE ACTION

*ITEM:8j

**ARIZONA DEPARTMENT OF TRANSPORTATION
MPD- Aeronautics Group
Project Committee Recommendations**

AIRPORT: ADOT Aeronautics Internal Project New Project
SPONSOR: ADOT Aeronautics Changed Project(s)
CATEGORY: N/A
PROJECT NUMBER: E6SMQ01X
MANAGER: Jeff Webbe
AIP NUMBER: N/A
DATE: April 29, 2026

Current Program Description	Fiscal Year	State Share	Sponsor Share	FAA Share	Total Amount	State Priority Number
ASM Updates	2026	\$50,000	N/A	N/A	\$50,000	
Revised Program Description	Fiscal Year	State Share	Sponsor Share	FAA Share	Total Amount	State Priority Number
ASM Updates	2026	\$61,249.95	N/A	N/A	\$61,249.95	
Justification:						
<ul style="list-style-type: none"> This project has increased by more than 15% due to the vendor's quote coming in higher than originally anticipated. 						

Aeronautics Recommends for PPAC action

Aeronautics State Engineer Approval: DocuSigned by:
Matthew Munden **Date:** 5/4/2026
C2D0E33391684F4...
Matthew Munden

FMS Review and Approval: Signed by:
Leticia Pineda-Daley **Date:** 5/4/2026
2EBD55F44A19406...
Leti Pineda-Daley

STATE ENGINEER'S REPORT
May 2026

The Status of Projects Under Construction report for **May 2026** shows **115** projects under construction valued at **\$2,976,041,832.24**. The transportation board awarded **11** projects during **May** valued at approximately **\$137.2** million.

During **May**, the Department finalized **4** projects valued at **\$5,649,669.06**. Projects where the final cost exceeded the contractors bid amount by more than 5% are detailed in your board package.

Fiscal Year to date we have finalized **80** projects. The total cost of these **80** projects has exceeded the contractors bid amount by **2.1%**. Deducting incentive/bonus payments, revisions, omissions and additional work paid for by others, fiscal year to date reduces this percentage to **0.2%**.

MONTHLY CONSTRUCTION REPORT

May 2026

PROJECTS UNDER CONSTRUCTION	115
MONETARY VALUE OF CONTRACTS	\$2,976,041,832.24
PAYMENTS MADE TO DATE	\$1,380,799,038.42
STATE PROJECTS	81
LOCAL GOVERNMENT	34
OTHER	
CONTRACTS EXECUTED IN MAY 2026	3
MONETARY AMOUNT OF CONTRACTS EXECUTED	\$5,924,948.20

FIELD REPORTS SECTION

EXT. 7301

Arizona Department of Transportation
Field Reports Section
Completed Contracts Fiscal Year 2026
 May, 2026

Project Number	Location District	State Estimate	Contractor	Bid Amount	Final Cost	Monetary	Percent
PE0-0-(229)T T032101C Working Days: 280 Days Used: 250	75th Ave to Skunk Creek Central District	3,241,917.00	J. BANICKI CONSTRUCTION, INC.	Low Bid = \$3,667,000.00	\$425,083.00 or 13.11% over State Estimate \$3,681,566.19	\$14,566.19	0.4 %
KNG-0-(212)T T042101C Working Days: 146 = 120 + 26 Days Used: 146	ANDY DEVINE AVE & VAR LOCATION NorthWest District	1,006,480.75	FALCONE BROS & ASSOCIATE INC.	Low Bid = \$1,061,908.25	\$55,427.50 or 5.51% over State Estimate \$1,451,242.21	\$389,333.96	36.7 %
ELY-0-(208)T T047201C Working Days: 110 Days Used: 106	Battaglia Dr and Tweedy Rd Int SouthCent District	120,360.00	ROADWAY ELECTRIC, LLC	Low Bid = \$89,417.00	(\$30,943.00) or 25.71% under State Estimate \$72,265.00	(\$17,152.00)	-19.2 %
YYV-0-(215)T T047701C Working Days: 90 Days Used: 75	Williamson Valley Rd and Staze NorthWest District	613,851.90	EARTH RESOURCES CORPORATION	Low Bid = \$479,845.00	(\$134,006.90) or 21.83% under State Estimate \$444,595.66	(\$35,249.34)	-7.3 %

Accumulation to Date (Fiscal Year 2026 ONLY)

No. of Contracts	Accumulative State Estimate	Bid Amount	Final Cost	Monetary	Percent
75	\$594,357,957.06	\$558,863,098.51	\$570,665,429.41	\$11,802,330.90	2.1%

Prepared By:

Checked By:

 Field Reports Unit, X7301

 IRENE DEL CASTILLO, FR Manager
 Field Reports, X7321

Completed Contracts (Fiscal Year 2026)

May, 2026

<u>Totals</u>	<u>No. of Contracts</u>	<u>State Estimate</u>	<u>Bid Amount</u>	<u>Final Cost</u>
# of Projects: 4	4	\$4,982,609.65	\$5,298,170.25	\$5,649,669.06
		<u>Monetary</u>		<u>Monetary</u>
		\$315,560.60		\$351,498.81

FINAL COST VS BID ADJUSTED

FISCAL YEAR 2026

<u>LESS ADJUSTMENTS FOR</u>								
<u>MONTH</u>	<u>CUMULATIVE FINAL COST</u>	<u>REVISIONS/ OMISSIONS #4 & #5</u>	<u>INCENTIVE/ BONUS #7</u>	<u>ADD'L WORK PD OTHERS #3</u>	<u>CUMULATIVE ADJ</u>	<u>CUMULATIVE BID AMOUNT</u>	<u>ADJUSTED FINAL COST</u>	<u>ADJ CUM</u>
Jul-25	\$ 54,558,985	\$ 431,654	\$ 236,985	\$ 193,403	\$ 862,042	\$ 53,935,164	\$ 53,696,943	-0.4%
Aug-25	\$ 241,101,839	\$ 2,006,302	\$ 1,729,462	\$ 23,129	\$ 4,620,935	\$ 234,085,662	\$ 236,480,904	1.0%
Sep-25	\$ 297,393,731	\$ 1,132,365	\$ 181,484	\$ -	\$ 5,934,784	\$ 290,923,391	\$ 291,458,947	0.2%
Oct-25	\$ 345,249,033	\$ 519,048	\$ 662,146	\$ -	\$ 7,115,978	\$ 340,235,832	\$ 338,133,054	-0.6%
Nov-25	\$ 371,550,307	\$ 254,115	\$ 282	\$ -	\$ 7,370,376	\$ 366,116,841	\$ 364,179,931	-0.5%
Dec-25	\$ 383,608,989	\$ 534,319	\$ -	\$ -	\$ 7,904,695	\$ 378,076,410	\$ 375,704,294	-0.6%
Jan-26	\$ 502,994,870	\$ 302,638	\$ 1,258,120	\$ -	\$ 9,465,452	\$ 496,001,800	\$ 493,529,418	-0.5%
Feb-26	\$ 521,714,945	\$ 446,981	\$ 58,780	\$ -	\$ 9,971,213	\$ 511,544,357	\$ 511,743,732	0.0%
Mar-26	\$ 538,313,398	\$ 5,842	\$ (4,392)	\$ -	\$ 9,972,663	\$ 527,691,032	\$ 528,340,736	0.1%
Apr-26	\$565,015,760	\$ 123,257	\$ 190,508	\$ -	\$ 10,286,428	\$ 553,564,928	\$ 554,729,333	0.2%
May-26	\$570,665,429	\$ 177,211	\$ (747)	\$ -	\$ 10,462,892	\$ 558,863,099	\$ 560,202,538	0.2%
Jun-26					\$ 10,462,892		\$ (10,462,892)	
		\$ 5,933,731	\$ 4,312,629	\$ 216,532	\$ 10,462,892			

CONTRACTS

Contracts: (Action as Noted)

Federal-Aid ("A" "B" "T" "D") projects do not need FHWA concurrence, but must comply with DBE regulations; other projects are subject to FHWA and/or local government concurrence and compliance with DBE regulations.

*ITEM:10a BOARD DISTRICT NO.: 3

BIDS OPENED: JUNE 05, 2026

HIGHWAY: NOGALES – TOMBSTONE HIGHWAY (SR 82)

SECTION: PATAGONIA LAKE ROAD TO PATAGONIA

COUNTY: SANTA CRUZ

ROUTE NO.: SR 82

PROJECT : TRACS: 082-A-NFA; 082 SC 012 F078101C

FUNDING: 100% STATE

LOW BIDDER: SUNLAND ASPHALT & CONSTRUCTION, LLC.

LOW BID AMOUNT: \$ 2,792,267.70

DEPARTMENT

ESTIMATE: \$ 3,663,715.00

\$ UNDER ESTIMATE: \$ 871,447.30

% UNDER ESTIMATE: 23.8%

PROJECT DBE GOAL: 0.0%

BIDDER DBE PLEDGE: N/A (DBE IFR effective 10/3/25)

NO. BIDDERS: 3

RECOMMENDATION: AWARD



CONTRACTS

*ITEM:10b BOARD DISTRICT NO.: 5

BIDS OPENED: MAY 15, 2026

HIGHWAY: ASH FORK – FLAGSTAFF – HOLBROOK HIGHWAY (I-40)

SECTION: I-40; I-17 / I-40 TRAFFIC INTERCHANGE TO COUNTRY CLUB DRIVE

COUNTY: COCONINO

ROUTE NO.: I-40

PROJECT : TRACS: 040-C(229)T: 040 CN 195 F051601C

FUNDING: 94.34% FED 5.66% STATE

LOW BIDDER: GRANITE CONSTRUCTION COMPANY

LOW BID AMOUNT: \$ 2,359,486.00

DEPARTMENT

ESTIMATE: \$ 1,794,740.50

\$ OVER ESTIMATE: \$ 564,745.50

% OVER ESTIMATE: 31.5%

PROJECT DBE GOAL: 0.0%

BIDDER DBE PLEDGE: N/A (DBE IFR effective 10/3/25)

NO. BIDDERS: 3

RECOMMENDATION: AWARD



1/14/2026

CONTRACTS

*ITEM:10c BOARD DISTRICT NO.: 6

BIDS OPENED: MAY 01, 2026

HIGHWAY: WICKENBURG - KINGMAN HIGHWAY (US 93)

SECTION: MP 175.5 – 117 NB & MP 176.0 – 176.5 SB, S. OF DATE CREEK

COUNTY: YAVAPAI

ROUTE NO.: US 93

PROJECT : TRACS: 093-B(224)T: 093 YV 175 F063601C

FUNDING: 94.30% FED 5.7% STATE

LOW BIDDER: FANN CONTRACTING, INC.

LOW BID AMOUNT: \$ 5,729,500.00

DEPARTMENT

ESTIMATE: \$ 4,811,757.90

\$ OVER ESTIMATE: \$ 917,742.10

% OVER ESTIMATE: 19.1%

PROJECT DBE GOAL: 0.0%

BIDDER DBE PLEDGE: N/A (DBE IFR effective 10/3/25)

NO. BIDDERS: 3

RECOMMENDATION: AWARD

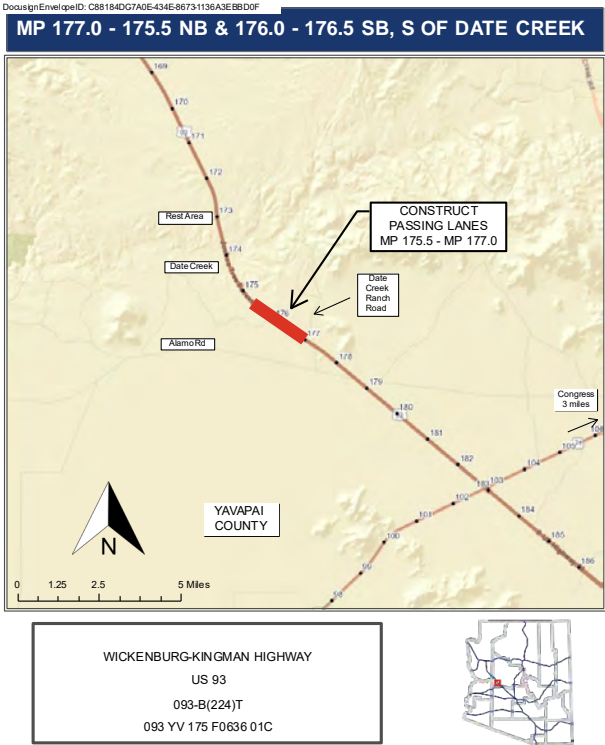

3/10/2025

*ITEM:10d BOARD DISTRICT NO.: 6
 BIDS OPENED: MAY 01, 2026
 HIGHWAY: CITY OF SOMERTON
 SECTION: COUNTY 15TH ST & AVE D
 COUNTY: YUMA
 ROUTE NO.: LOCAL
 PROJECT : TRACS: SOM-0(208)T; 0000 YU SOM T051701C
 FUNDING: 94.30% FED 5.70% LOCAL
 LOW BIDDER: AJP ELECTRIC, INC.
 LOW BID AMOUNT: \$ 356,467.35
 DEPARTMENT
 ESTIMATE: \$ 519,434.00
 \$ UNDER ESTIMATE: \$ 162,966.65
 % UNDER ESTIMATE: 31.4%
 PROJECT DBE GOAL: 0.0%
 BIDDER DBE PLEDGE: N/A (DBE IFR effective 10/3/25)
 NO. BIDDERS: 3
 RECOMMENDATION: AWARD



10/2/2025



ARIZONA DEPARTMENT OF TRANSPORTATION
 PROJECT DELIVERY AND OPERATIONS DIVISION
 CONTRACTS AND SPECIFICATIONS SECTION

BID RESULTS

Completion Date:

140 Working Days

The proposed project is located in Yavapai County, on State Route 89, approximately 45 miles north of the City of Prescott. The project begins at milepost 353.67 and ends at milepost 354.62 (North of Drake). The proposed work consists of adding a new passing lane for the north bound direction. The work includes widening roadway mainline and shoulder, signing and pavement markings. The work also includes seeding, installing ground-in rumble strips, and other related work.

Bid Opening Date : 5/15/2026, Prequalification Required, Engineer Specialist : Patwary Mohammed

Project No.	Highway Termini	Location	Item
089 YV 353 F063401C 089-B-(223)T	PRESCOTT-ASH FORK HWY (SR 89)	MP 349.5 - MP 351 NorthWest District	103635

Rank	Bid Amount	Contractor Name	Address of Contractor
1	\$2,947,005.00	EARTH RESOURCES CORPORATION	300 S. LATILLA LANE DEWEY, AZ 86327-
2	\$3,272,777.77	FANN CONTRACTING, INC	PO BOX 4356 PRESCOTT, AZ 86302-
	\$3,355,118.00	DEPARTMENT	
3	\$3,435,484.99	ASPHALT PAVING & SUPPLY, INC.	2425 NORTH GLASSFORD HILL RD PRESCOTT VALLEY, AZ 86314-
4	\$4,255,555.00	HAWK CONTRACTING LLC	1022 E. LOYOLA DRIVE TEMPE, AZ 85282-

Apparent Low Bidder is 12.2% Under Department Estimate (Difference = (\$408,113.00))

ARIZONA DEPARTMENT OF TRANSPORTATION

ADVERTISEMENT FOR BIDS

BID OPENING: FRIDAY, MAY 15, 2026, AT 11:00 A.M. (M.S.T.)

TRACS NO 089 YV 0353 F063401C
PROJECT NO 089-B(223)T
TERMINI PRESCOTT-ASH FORK HWY (SR 89)
LOCATION MP 353.67 TO MP 354.62 (NORTH OF DRAKE)

ROUTE NO.	MILEPOST	DISTRICT	ITEM NO.
089	353.67 to 354.62	NORTHWEST	103635

The amount programmed for this contract is \$4,560,000. The location and description of the proposed work are as follows:

The proposed project is located in Yavapai County, on State Route 89, approximately 45 miles north of the City of Prescott. The project begins at milepost 353.67 and ends at milepost 354.62 (North of Drake). The proposed work consists of adding a new passing lane for the north bound direction. The work includes widening roadway mainline and shoulder, signing and pavement markings. The work also includes seeding, installing ground-in rumble strips, and other related work.

The time allowed for the completion of the work included in this contract will be 140 working days.

The Arizona Department of Transportation, in accordance with the provisions of Title VI of the Civil Rights Act of 1964 (78 Stat. 252, 42 U.S.C. §§ 2000d to §§ 2000d-4) and the Regulations, hereby notifies all bidders that it will affirmatively ensure that any contract entered into pursuant to this advertisement, Disadvantaged Business Enterprises will be afforded full and fair opportunity to submit bids in response to this invitation and will not be discriminated against on the grounds of race, color, or national origin in consideration for an award.

Contract documents, and other project documents, if applicable, are available as electronic files, at no charge, from the Department's website through the ADOT Contracts and Specifications Group (<https://azdot.gov/business/contracts-and-specifications/current-advertisements>).

Documents will be available within one week following the advertisement for bids.

To submit a valid bid, the bidder must (1) have prequalification from the Department as necessary for the project, and (2) be included on the project Plansholder List as a Prime.

The Application for Contractor Prequalification may be obtained from the Contracts and Specifications website.

This project requires electronic bidding. If a request for approval to bid as a Prime Contractor is received less than five working days prior to bid opening, the Department cannot guarantee the request will be acted on.

This contract is subject to the provisions of Arizona Revised Statutes Section 42-5075 -- Prime contracting classification; exemptions; definitions.

No award will be made to any contractor who is not a duly licensed contractor in accordance with Arizona Revised Statutes 32-1101 through 32-1170.03.

All labor employed on this project shall be paid in accordance with the minimum wage rates shown in the General Wage Decision. These rates have been determined in accordance with the requirements of the law and issued by the Secretary of Labor for this project. The wage scale is on file in Contracts and Specifications Section and copies may be obtained at all reasonable times.

Persons that require a reasonable accommodation based on language or disability should contact ADOT's Contracts and Specifications Office by phone (602) 712-7221. Requests should be made as early as possible to ensure the State has an opportunity to address the accommodation.

Las personas que requieran asistencia (dentro de lo razonable) ya sea por el idioma o discapacidad deben ponerse en contacto con ADOT (602) 712-7221.

The bidder shall provide an electronic proposal guaranty payable to the Arizona Department of Transportation for 10 percent of the amount of the bid.

Prior to the bid opening date, any questions pertaining to the project documents shall be submitted to the Department in a written format through the Bid Express (Bidx) website at <https://www.bidx.com/az/lettings>. Questions shall be submitted through the Questions and Answers (Q&A) link located within the corresponding letting date and project proposal number links. The Department may not answer all questions, and any decision on whether a question is answered will be within the sole discretion of the Department. Any questions received less than three working days prior to the bid opening date may not be answered.

The Engineering Specialist assigned to this project is: Mohammed Patwary, MPatwary@azdot.gov, any correspondence with the Engineering Specialist is subject to posting onto Bidx through the project's Q&A link. Answers to questions will not be given verbally, but will be posted exclusively to the Bidx website.

Brahama Singh, PE,
Group Manager,
Contracts & Specifications

Project Advertised on: 04/01/2026



ARIZONA DEPARTMENT OF TRANSPORTATION
 PROJECT DELIVERY AND OPERATIONS DIVISION
 CONTRACTS AND SPECIFICATIONS SECTION

BID RESULTS

Completion Date:

140 Working Days

The proposed work is located in Mohave County on US 93 between mileposts 127.7 and 131.0, near Wikieup. The work consists of milling the existing asphaltic concrete and replacing it with new asphaltic concrete. The work also consists of guardrail; striping; signing; seeding; and other related work.

Bid Opening Date : 5/8/2026, Prequalification Required, Engineer Specialist : Brandon Campbell

Project No.	Highway Termini	Location	Item
093 MO 127 F076001C 093-B-(227)T	KINGMAN - WICKENBURG HIGHWAY (US 93)	Cholla Canyon Ranch Road - Eas NorthWest District	104405

Rank	Bid Amount	Contractor Name	Address of Contractor
1	\$9,631,964.10	FNF CONSTRUCTION, INC.	115 S. 48TH STREET TEMPE, AZ 85281-8504
2	\$10,820,000.00	FANN CONTRACTING, INC	PO BOX 4356 PRESCOTT, AZ 86302-
	\$11,003,651.20	DEPARTMENT	

Apparent Low Bidder is 12.5% Under Department Estimate (Difference = (\$1,371,687.10))

This project requires electronic bidding. If a request for approval to bid as a Prime Contractor is received less than five working days prior to bid opening, the Department cannot guarantee the request will be acted on.

This contract is subject to the provisions of Arizona Revised Statutes Section 42-5075 -- Prime contracting classification; exemptions; definitions.

No award will be made to any contractor who is not a duly licensed contractor in accordance with Arizona Revised Statutes 32-1101 through 32-1170.03.

All labor employed on this project shall be paid in accordance with the minimum wage rates shown in the General Wage Decision. These rates have been determined in accordance with the requirements of the law and issued by the Secretary of Labor for this project. The wage scale is on file in Contracts and Specifications Section and copies may be obtained at all reasonable times.

Persons that require a reasonable accommodation based on language or disability should contact ADOT's Contracts and Specifications Office by phone (602) 712-7221. Requests should be made as early as possible to ensure the State has an opportunity to address the accommodation.

Las personas que requieran asistencia (dentro de lo razonable) ya sea por el idioma o discapacidad deben ponerse en contacto con ADOT (602) 712-7221.

The bidder shall provide an electronic proposal guaranty payable to the Arizona Department of Transportation for 10 percent of the amount of the bid.

Prior to the bid opening date, any questions pertaining to the project documents shall be submitted to the Department in a written format through the Bid Express (Bidx) website at <https://www.bidx.com/az/lettings>. Questions shall be submitted through the Questions and Answers (Q&A) link located within the corresponding letting date and project proposal number links. The Department may not answer all questions, and any decision on whether a question is answered will be within the sole discretion of the Department. Any questions received less than three working days prior to the bid opening date may not be answered.

The Engineering Specialist assigned to this project is: Brandon Campbell, BCampbell2@azdot.gov, any correspondence with the Engineering Specialist is subject to posting onto Bidx through the project's Q&A link. Answers to questions will not be given verbally, but will be posted exclusively to the Bidx website.

Brahama Singh, PE,
Group Manager,
Contracts & Specifications

Project Advertised on: 02/06/26



ARIZONA DEPARTMENT OF TRANSPORTATION
 PROJECT DELIVERY AND OPERATIONS DIVISION
 CONTRACTS AND SPECIFICATIONS SECTION

BID RESULTS

Completion Date:

350 Working Days

The proposed project is located in Yavapai County, on SR-96 at the Santa Maria River Bridge. The work consists of removing and replacing the existing bridge. Additional work includes asphaltic concrete pavement replacement, hot applied chip seal coat with fog coat application, cattle guard replacement, guardrail replacement, pavement marking, and other related work.

Bid Opening Date : 5/15/2026, Prequalification Required, Engineer Specialist : Brandon Campbell

Project No.	Highway Termini	Location	Item
096 YV 010 F058401C 096-A-(200)T	BAGDAD - HILLSIDE HIGHWAY (SR 96)	Santa Maria River Bridge NorthWest District	100216

Rank	Bid Amount	Contractor Name	Address of Contractor
1	\$9,480,448.90	FNF CONSTRUCTION, INC.	115 S. 48TH STREET TEMPE, AZ 85281-8504
2	\$9,763,851.95	SEMA CONSTRUCTION, INC.	7353 S EAGLE STREET CENTENNIAL, CO 80112-
3	\$9,822,075.00	J. BANICKI CONSTRUCTION, INC.	4720 E. Cotton Gin Loop, Suite 240 Phoenix, AZ 85040-
	\$9,882,938.70	DEPARTMENT	
4	\$10,183,708.00	AMES CONSTRUCTION, INC.	8333 E. HARTFORD DRIVE SCOTTSDALE, AZ 85255-
5	\$10,920,829.00	TECHNOLOGY CONSTRUCTION, INC.	5430 SIDE ROAD PRESCOTT, AZ 86301-
6	\$11,389,551.70	C S CONSTRUCTION, INC.	22023 N 20TH AVE SUITE A PHOENIX, AZ 85027-

Rank	Bid Amount	Contractor Name	Address of Contractor
7	\$11,498,964.10	SKANSKA USA CIVIL WEST CALIFORNIA DISTRICT INC	1995 AGUA MANSA ROAD RIVERSIDE, CA 92509-
8	\$13,577,358.78	PULICE CONSTRUCTION, INC.	8660 E. HARTFORD DRIVE, SUITE 305 SCOTTSDALE, AZ 85255-

Apparent Low Bidder is 4.1% Under Department Estimate (Difference = (\$402,489.80))

ARIZONA DEPARTMENT OF TRANSPORTATION

ADVERTISEMENT FOR BIDS

BID OPENING: FRIDAY, MAY 15, 2026, AT 11:00 A.M. (M.S.T.)

TRACS NO 096 YV 010 F0584 01C
PROJECT NO 096-A(200)T
TERMINI BAGDAD-HILLSIDE HWY (SR 96)
LOCATION SANTA MARIA RIVER BRIDGE

ROUTE NO.	MILEPOST	DISTRICT	ITEM NO.
SR 96	10.89 to 11.52	NORTHWEST	100216

The amount programmed for this contract is \$14,500,000. The location and description of the proposed work are as follows:

The proposed project is located in Yavapai County, on SR-96 at the Santa Maria River Bridge. The work consists of removing and replacing the existing bridge. Additional work includes asphaltic concrete pavement replacement, hot applied chip seal coat with fog coat application, cattle guard replacement, guardrail replacement, pavement marking, and other related work.

The time allowed for the completion of the work included in this contract will be 350 working days.

The Arizona Department of Transportation, in accordance with the provisions of Title VI of the Civil Rights Act of 1964 (78 Stat. 252, 42 U.S.C. §§ 2000d to §§ 2000d-4) and the Regulations, hereby notifies all bidders that it will affirmatively ensure that any contract entered into pursuant to this advertisement, Disadvantaged Business Enterprises will be afforded full and fair opportunity to submit bids in response to this invitation and will not be discriminated against on the grounds of race, color, or national origin in consideration for an award.

Contract documents, and other project documents, if applicable, are available as electronic files, at no charge, from the Department's website through the ADOT Contracts and Specifications Group (<https://azdot.gov/business/contracts-and-specifications/current-advertisements>).

Documents will be available within one week following the advertisement for bids.

To submit a valid bid, the bidder must (1) have prequalification from the Department as necessary for the project, and (2) be included on the project Plansholder List as a Prime.

The Application for Contractor Prequalification may be obtained from the Contracts and Specifications website.

This project requires electronic bidding. If a request for approval to bid as a Prime Contractor is received less than five working days prior to bid opening, the Department cannot guarantee the request will be acted on.

This contract is subject to the provisions of Arizona Revised Statutes Section 42-5075 -- Prime contracting classification; exemptions; definitions.

No award will be made to any contractor who is not a duly licensed contractor in accordance with Arizona Revised Statutes 32-1101 through 32-1170.03.

All labor employed on this project shall be paid in accordance with the minimum wage rates shown in the General Wage Decision. These rates have been determined in accordance with the requirements of the law and issued by the Secretary of Labor for this project. The wage scale is on file in Contracts and Specifications Section and copies may be obtained at all reasonable times.

Persons that require a reasonable accommodation based on language or disability should contact ADOT's Contracts and Specifications Office by phone (602) 712-7221. Requests should be made as early as possible to ensure the State has an opportunity to address the accommodation.

Las personas que requieran asistencia (dentro de lo razonable) ya sea por el idioma o discapacidad deben ponerse en contacto con ADOT (602) 712-7221.

The bidder shall provide an electronic proposal guaranty payable to the Arizona Department of Transportation for 10 percent of the amount of the bid.

Prior to the bid opening date, any questions pertaining to the project documents shall be submitted to the Department in a written format through the Bid Express (Bidx) website at <https://www.bidx.com/az/lettings>. Questions shall be submitted through the Questions and Answers (Q&A) link located within the corresponding letting date and project proposal number links. The Department may not answer all questions, and any decision on whether a question is answered will be within the sole discretion of the Department. Any questions received less than three working days prior to the bid opening date may not be answered.

The Engineering Specialist assigned to this project is: Brandon Campbell, bcampbell2@azdot.gov, any correspondence with the Engineering Specialist is subject to posting onto Bidx through the project's Q&A link. Answers to questions will not be given verbally, but will be posted exclusively to the Bidx website.

Brahama Singh, PE,
Group Manager,
Contracts & Specifications

Project Advertised on: 3/20/26



ARIZONA DEPARTMENT OF TRANSPORTATION
PROJECT DELIVERY AND OPERATIONS DIVISION
CONTRACTS AND SPECIFICATIONS SECTION

BID RESULTS

Completion Date:

195 Working Days

The proposed work is located in Graham County, on US-191 between MP 132.04 and MP 134.57, near Safford. The proposed work consists of constructing passing lanes in both the Northbound (NB) and Southbound (SB) directions, the work also includes, constructing a reinforced concrete box culvert, installing fence, drainage improvements, installation of rumble strips, placing riprap, installation of signs, applying pavement marking, and other related work.

Bid Opening Date : 5/8/2026, Prequalification Required, Engineer Specialist : Yusuf Kadem

Project No.	Highway Termini	Location	Item
191 GH 132 F070801C 191-C-(227)T	SAFFORD-SPRINGERVILLE HWY (US - 191)	US 70 to MP 134 SouthEast District	103645

Rank	Bid Amount	Contractor Name	Address of Contractor
1	\$2,983,902.89	SHOW LOW CONSTRUCTION, INC.	1801 W. DEUCE OF CLUBS, SUITE 300 SHOW LOW, AZ 85901-
	\$3,185,509.75	DEPARTMENT	
	\$3,186,317.75	DEPARTMENT	
	\$3,188,818.75	DEPARTMENT	
	\$3,189,626.75	DEPARTMENT	
2	\$3,396,352.60	RUMMEL CONSTRUCTION, INC	7520 E. ADOBE DRIVE SCOTTSDALE, AZ 85255-

Rank	Bid Amount	Contractor Name	Address of Contractor
3	\$4,734,086.25	W. W. CLYDE & CO.	869 N. 1500 W. Orem, UT 84057-

Apparent Low Bidder is 6.4% Under Department Estimate (Difference = (\$204,915.86))

ARIZONA DEPARTMENT OF TRANSPORTATION

ADVERTISEMENT FOR BIDS

BID OPENING: FRIDAY MAY 08, 2026, AT 11:00 A.M. (M.S.T.)

TRACS NO 191 GH 132 F0708 01C
PROJECT NO 191-C(227)T
TERMINI SAFFORD-SPRINGERVILLE HWY (US-191)
LOCATION US 70 - MP 134

ROUTE NO.	MILEPOST	DISTRICT	ITEM NO.
US-191	132.040 to 133.570	SOUTHEAST	103645

This project contains option bidding.

The amount programmed for this contract is \$4,671,000. The location and description of the proposed work are as follows:

The proposed work is located in Graham County, on US-191 between MP 132.04 and MP 134.57, near Safford. The proposed work consists of constructing passing lanes in both the Northbound (NB) and Southbound (SB) directions, the work also includes, constructing a reinforced concrete box culvert, installing fence, drainage improvements, installation of rumble strips, placing riprap, installation of signs, applying pavement marking, and other related work.

The time allowed for the completion of the work included in this contract will be 195 working days.

The Arizona Department of Transportation, in accordance with the provisions of Title VI of the Civil Rights Act of 1964 (78 Stat. 252, 42 U.S.C. §§ 2000d to §§ 2000d-4) and the Regulations, hereby notifies all bidders that it will affirmatively ensure that any contract entered into pursuant to this advertisement, Disadvantaged Business Enterprises will be afforded full and fair opportunity to submit bids in response to this invitation and will not be discriminated against on the grounds of race, color, or national origin in consideration for an award.

Contract documents, and other project documents, if applicable, are available as electronic files, at no charge, from the Department's website through the ADOT Contracts and Specifications Group (<https://azdot.gov/business/contracts-and-specifications/current-advertisements>).

Documents will be available within one week following the advertisement for bids.

To submit a valid bid, the bidder must (1) have prequalification from the Department as necessary for the project, and (2) be included on the project Plansholder List as a Prime.

The Application for Contractor Prequalification may be obtained from the Contracts and Specifications website.

This project requires electronic bidding. If a request for approval to bid as a Prime Contractor is received less than five working days prior to bid opening, the Department cannot guarantee the request will be acted on.

This contract is subject to the provisions of Arizona Revised Statutes Section 42-5075 -- Prime contracting classification; exemptions; definitions.

No award will be made to any contractor who is not a duly licensed contractor in accordance with Arizona Revised Statutes 32-1101 through 32-1170.03.

All labor employed on this project shall be paid in accordance with the minimum wage rates shown in the General Wage Decision. These rates have been determined in accordance with the requirements of the law and issued by the Secretary of Labor for this project. The wage scale is on file in Contracts and Specifications Section and copies may be obtained at all reasonable times.

Persons that require a reasonable accommodation based on language or disability should contact ADOT's Contracts and Specifications Office by phone (602) 712-7221. Requests should be made as early as possible to ensure the State has an opportunity to address the accommodation.

Las personas que requieran asistencia (dentro de lo razonable) ya sea por el idioma o discapacidad deben ponerse en contacto con ADOT (602) 712-7221.

The bidder shall provide an electronic proposal guaranty payable to the Arizona Department of Transportation for 10 percent of the amount of the bid.

Prior to the bid opening date, any questions pertaining to the project documents shall be submitted to the Department in a written format through the Bid Express (Bidx) website at <https://www.bidx.com/az/lettings>. Questions shall be submitted through the Questions and Answers (Q&A) link located within the corresponding letting date and project proposal number links. The Department may not answer all questions, and any decision on whether a question is answered will be within the sole discretion of the Department. Any questions received less than three working days prior to the bid opening date may not be answered.

The Engineering Specialist assigned to this project is: Yusuf Kadem, YKadem@azdot.gov, any correspondence with the Engineering Specialist is subject to posting onto Bidx through the project's Q&A link. Answers to questions will not be given verbally, but will be posted exclusively to the Bidx website.



For Brahma Singh, PE,
Group Manager,
Contracts & Specifications

Project Advertised on: 03/25/2026



ARIZONA DEPARTMENT OF TRANSPORTATION
PROJECT DELIVERY AND OPERATIONS DIVISION
CONTRACTS AND SPECIFICATIONS SECTION

BID RESULTS

Completion Date:

70 Working Days

The proposed project is located on an extension of Central Avenue, approximately 0.6 miles southwest of the junction of State Route 69, within Yavapai County, Arizona. The work consists of rehabilitating the existing bridge, replacing guardrail and reconstructing the roadway approaches, and other related work.

Bid Opening Date : 5/1/2026, Prequalification Required, Engineer Specialist : Brandon Campbell

Project No.	Highway Termini	Location	Item
0000 YV YV T051301C YV-0-(220)T	YAVAPAI COUNTY	Big Bug Creek Bridge NorthWest District	104439

Rank	Bid Amount	Contractor Name	Address of Contractor
1	\$442,970.70	D B A CONSTRUCTION INC.	P.O. BOX 63035 PHOENIX, AZ 85082-3035
2	\$454,379.00	J. BANICKI CONSTRUCTION, INC.	4720 E. Cotton Gin Loop, Suite 240 Phoenix, AZ 85040-
	\$491,619.00	DEPARTMENT	
3	\$609,600.00	TECHNOLOGY CONSTRUCTION, INC.	5430 SIDE ROAD PRESCOTT, AZ 86301-

Apparent Low Bidder is 9.9% Under Department Estimate (Difference = (\$48,648.30))

ARIZONA DEPARTMENT OF TRANSPORTATION

ADVERTISEMENT FOR BIDS

BID OPENING: FRIDAY, MAY 1, 2026, AT 11:00 A.M. (M.S.T.)

TRACS NO 0000 YV YYV T0513 01C
PROJECT NO YYV-0(220)T
TERMINI YAVAPAI COUNTY
LOCATION BIG BUG CREEK BRIDGE

ROUTE NO.	MILEPOST	DISTRICT	ITEM NO.
N/A	N/A	NORTHWEST	104439

The amount programmed for this contract is \$640,000. The location and description of the proposed work are as follows:

The proposed project is located on an extension of Central Avenue, approximately 0.6 miles southwest of the junction of State Route 69, within Yavapai County, Arizona. The work consists of rehabilitating the existing bridge, replacing guardrail and reconstructing the roadway approaches, and other related work.

The time allowed for the completion of the work included in this contract will be 70 working days.

The Arizona Department of Transportation, in accordance with the provisions of Title VI of the Civil Rights Act of 1964 (78 Stat. 252, 42 U.S.C. §§ 2000d to §§ 2000d-4) and the Regulations, hereby notifies all bidders that it will affirmatively ensure that any contract entered into pursuant to this advertisement, Disadvantaged Business Enterprises will be afforded full and fair opportunity to submit bids in response to this invitation and will not be discriminated against on the grounds of race, color, or national origin in consideration for an award.

Contract documents, and other project documents, if applicable, are available as electronic files, at no charge, from the Department's website through the ADOT Contracts and Specifications Group (<https://azdot.gov/business/contracts-and-specifications/current-advertisements>).

Documents will be available within one week following the advertisement for bids.

To submit a valid bid, the bidder must (1) have prequalification from the Department as necessary for the project, and (2) be included on the project Plansholder List as a Prime.

The Application for Contractor Prequalification may be obtained from the Contracts and Specifications website.

This project requires electronic bidding. If a request for approval to bid as a Prime Contractor is received less than five working days prior to bid opening, the Department cannot guarantee the request will be acted on.

This contract is subject to the provisions of Arizona Revised Statutes Section 42-5075 -- Prime contracting classification; exemptions; definitions.

No award will be made to any contractor who is not a duly licensed contractor in accordance with Arizona Revised Statutes 32-1101 through 32-1170.03.

All labor employed on this project shall be paid in accordance with the minimum wage rates shown in the General Wage Decision. These rates have been determined in accordance with the requirements of the law and issued by the Secretary of Labor for this project. The wage scale is on file in Contracts and Specifications Section and copies may be obtained at all reasonable times.

Persons that require a reasonable accommodation based on language or disability should contact ADOT's Contracts and Specifications Office by phone (602) 712-7221. Requests should be made as early as possible to ensure the State has an opportunity to address the accommodation.

Las personas que requieran asistencia (dentro de lo razonable) ya sea por el idioma o discapacidad deben ponerse en contacto con ADOT (602) 712-7221.

The bidder shall provide an electronic proposal guaranty payable to the Arizona Department of Transportation for 10 percent of the amount of the bid.

Prior to the bid opening date, any questions pertaining to the project documents shall be submitted to the Department in a written format through the Bid Express (Bidx) website at <https://www.bidx.com/az/lettings>. Questions shall be submitted through the Questions and Answers (Q&A) link located within the corresponding letting date and project proposal number links. The Department may not answer all questions, and any decision on whether a question is answered will be within the sole discretion of the Department. Any questions received less than three working days prior to the bid opening date may not be answered.

The Engineering Specialist assigned to this project is: Brandon Campbell, bcampbell2@azdot.gov, any correspondence with the Engineering Specialist is subject to posting onto Bidx through the project's Q&A link. Answers to questions will not be given verbally, but will be posted exclusively to the Bidx website.

Brahama Singh, PE,
Group Manager,
Contracts & Specifications

Project Advertised on: 3/20/26



ARIZONA DEPARTMENT OF TRANSPORTATION
 PROJECT DELIVERY AND OPERATIONS DIVISION
 CONTRACTS AND SPECIFICATIONS SECTION

BID RESULTS

Completion Date:

100 Working Days

The proposed work is located in Santa Cruz County on SR82 between mileposts 12.30 and 19.00 between Patagonia Lake Road and Patagonia. The proposed work consists of milling and placing a hot applied chip seal coat, followed by applying micro-surfacing. The project also includes spot repair work by milling and replacing with asphaltic concrete. Additional work includes replacing pavement markings and other miscellaneous work.

Bid Opening Date : 6/5/2026, Prequalification Required, Engineer Specialist : Mike Wechselberger

Project No.	Highway Termini	Location	Item
082 SC 012 F078101C 082-A-(NFA)	NOGALES - TOMBSTONE HIGHWAY	Patagonia Lake Rd - Patagonia SouthCent District	104975

Rank	Bid Amount	Contractor Name	Address of Contractor
1	\$2,792,267.70	SUNLAND ASPHALT & CONSTRUCTION LLC	1625 E. NORTHERN AVENUE PHOENIX, AZ 85020-
2	\$2,961,789.00	CACTUS TRANSPORT II, LLC.	8211 WEST SHERMAN STREET TOLLESON, AZ 85353-
3	\$3,233,120.00	VSS INTERNATIONAL, INC.	3785 Channel Drive West Sacramento, CA 95691-
	\$3,663,715.00	DEPARTMENT	

Apparent Low Bidder is 23.8% Under Department Estimate (Difference = (\$871,447.30))

ARIZONA DEPARTMENT OF TRANSPORTATION

ADVERTISEMENT FOR BIDS

BID OPENING: FRIDAY, JUNE 5, 2026, AT 11:00 A.M. (M.S.T.)

TRACS NO 082 SC 012 F0781 01C
PROJECT NO 082-A-NFA
TERMINI NOGALES – TOMBSTONE HIGHWAY (SR 82)
LOCATION PATAGONIA LAKE ROAD TO PATAGONIA

ROUTE NO.	MILEPOST	DISTRICT	ITEM NO.
SR82	12.30 to 19.00	SOUTHCENTRAL	104975

It is the intent of the Department to recommend this project for award consideration at the Transportation Board meeting on Friday, June 19th, 2026

The amount programmed for this contract is \$4,820,000. The location and description of the proposed work are as follows:

The proposed work is located in Santa Cruz County on SR82 between mileposts 12.30 and 19.00 between Patagonia Lake Road and Patagonia. The proposed work consists of milling and placing a hot applied chip seal coat, followed by applying micro-surfacing. The project also includes spot repair work by milling and replacing with asphaltic concrete. Additional work includes replacing pavement markings and other miscellaneous work.

The time allowed for the completion of the work included in this contract will be 100 working days.

This contract includes an abbreviated period for execution of contract and start of work.

The Arizona Department of Transportation, in accordance with the provisions of Title VI of the Civil Rights Act of 1964 (78 Stat. 252, 42 U.S.C. §§ 2000d to §§ 2000d-4) and the Regulations, hereby notifies all bidders that it will affirmatively ensure that any contract entered into pursuant to this advertisement, Disadvantaged Business Enterprises will be afforded full and fair opportunity to submit bids in response to this invitation and will not be discriminated against on the grounds of race, color, or national origin in consideration for an award.

Contract documents, and other project documents, if applicable, are available as electronic files, at no charge, from the Department’s website through the ADOT Contracts and Specifications Group (<https://azdot.gov/business/contracts-and-specifications/current-advertisements>).

Documents will be available within one week following the advertisement for bids.

To submit a valid bid, the bidder must (1) have prequalification from the Department as necessary for the project, and (2) be included on the project Plansholder List as a Prime.

The Application for Contractor Prequalification may be obtained from the Contracts and Specifications website.

This project requires electronic bidding. If a request for approval to bid as a Prime Contractor is received less than five working days prior to bid opening, the Department cannot guarantee the request will be acted on.

This contract is subject to the provisions of Arizona Revised Statutes Section 42-5075 -- Prime contracting classification; exemptions; definitions.

No proposal will be accepted from any contractor who is not a duly licensed contractor in accordance with Arizona Revised Statutes 32-1101 through 32-1170.03.

Persons that require a reasonable accommodation based on language or disability should contact ADOT's Contracts and Specifications Office by phone (602) 712-7221. Requests should be made as early as possible to ensure the State has an opportunity to address the accommodation.

Las personas que requieran asistencia (dentro de lo razonable) ya sea por el idioma o discapacidad deben ponerse en contacto con ADOT (602) 712-7221.

The bidder shall provide an electronic proposal guaranty payable to the Arizona Department of Transportation for 10 percent of the amount of the bid.

Prior to the bid opening date, any questions pertaining to the project documents shall be submitted to the Department in a written format through the Bid Express (Bidx) website at <https://www.bidx.com/az/lettings>. Questions shall be submitted through the Questions and Answers (Q&A) link located within the corresponding letting date and project proposal number links. The Department may not answer all questions, and any decision on whether a question is answered will be within the sole discretion of the Department. Any questions received less than three working days prior to the bid opening date may not be answered.

The Engineering Specialist assigned to this project is: Mike Wechselberger, mwechselberger@azdot.gov, any correspondence with the Engineering Specialist is subject to posting onto Bidx through the project's Q&A link. Answers to questions will not be given verbally but will be posted exclusively to the Bidx website.

Brahama Singh, PE,
Group Manager,
Contracts & Specifications

Project Advertised on: May 15, 2026



ARIZONA DEPARTMENT OF TRANSPORTATION
 PROJECT DELIVERY AND OPERATIONS DIVISION
 CONTRACTS AND SPECIFICATIONS SECTION

BID RESULTS

Completion Date:

210 Working Days

The proposed project is located on I-40 from the I-17/I-40 Traffic Interchange (MP 195) to Country Club Drive (MP 201) within Coconino County. The proposed work consists of the installation of closed circuit television cameras, fiber optic cable, dynamic message signs, butterfly sign structures, and other related work.

Bid Opening Date : 5/15/2026, Prequalification Required, Engineer Specialist : Mowery-Racz Thomas

Project No.	Highway Termini	Location	Item
040 CN 195 F051601C 040-C-(229)T	ASH FORK-FLAGSTAFF-HOLBROOK HIGHWAY (I-40)	I-17 to Country Club Dr. NorthCent District	103298

Rank	Bid Amount	Contractor Name	Address of Contractor
	\$1,794,740.50	DEPARTMENT	
1	\$2,359,486.00	GRANITE CONSTRUCTION COMPANY	4115 E ILLINOIS ST TUCSON, AZ 85714-
2	\$2,469,910.00	MICHIANA CONTRACTING, INC.	7843 LILAC ROAD PLYMOUTH, IN 46563-
3	\$2,489,640.00	C S CONSTRUCTION, INC.	22023 N 20TH AVE SUITE A PHOENIX, AZ 85027-

Apparent Low Bidder is 31.5% Over Department Estimate (Difference = \$564,745.50)

ARIZONA DEPARTMENT OF TRANSPORTATION

ADVERTISEMENT FOR BIDS

BID OPENING: FRIDAY, MAY 15, 2026, AT 11:00 A.M. (M.S.T.)

TRACS NO: 040 CN 195 F0516 01C
PROJECT NO: 040-C(229)T
TERMINI: ASH FORK – FLAGSTAFF – HOLBROOK HIGHWAY (I-40)
LOCATION: I-40; I-17/I-40 Traffic Interchange to Country Club Drive

ROUTE NO.	MILEPOST	DISTRICT	ITEM NO.
I-40	195 to 201	NorthCentral	103298

The amount programmed for this contract is \$2,460,000. The location and description of the proposed work are as follows:

The proposed project is located on I-40 from the I-17/I-40 Traffic Interchange (MP 195) to Country Club Drive (MP 201) within Coconino County. The proposed work consists of the installation of closed circuit television cameras, fiber optic cable, dynamic message signs, butterfly sign structures, and other related work.

The time allowed for the completion of the work included in this contract will be 160 working days.

The Arizona Department of Transportation, in accordance with the provisions of Title VI of the Civil Rights Act of 1964 (78 Stat. 252, 42 U.S.C. §§ 2000d to §§ 2000d-4) and the Regulations, hereby notifies all bidders that it will affirmatively ensure that any contract entered into pursuant to this advertisement, Disadvantaged Business Enterprises will be afforded full and fair opportunity to submit bids in response to this invitation and will not be discriminated against on the grounds of race, color, or national origin in consideration for an award.

Contract documents, and other project documents, if applicable, are available as electronic files, at no charge, from the Department's website through the ADOT Contracts and Specifications Group (<https://azdot.gov/business/contracts-and-specifications/current-advertisements>).

Documents will be available within one week following the advertisement for bids.

To submit a valid bid, the bidder must (1) have prequalification from the Department as necessary for the project, and (2) be included on the project Plansholder List as a Prime.

The Application for Contractor Prequalification may be obtained from the Contracts and Specifications website.

This project requires electronic bidding. If a request for approval to bid as a Prime Contractor is received less than five working days prior to bid opening, the Department cannot guarantee the request will be acted on.

This contract is subject to the provisions of Arizona Revised Statutes Section 42-5075 -- Prime contracting classification; exemptions; definitions.

No award will be made to any contractor who is not a duly licensed contractor in accordance with Arizona Revised Statutes 32-1101 through 32-1170.03.

All labor employed on this project shall be paid in accordance with the minimum wage rates shown in the General Wage Decision. These rates have been determined in accordance with the requirements of the law and issued by the Secretary of Labor for this project. The wage scale is on file in Contracts and Specifications Section and copies may be obtained at all reasonable times.

Persons that require a reasonable accommodation based on language or disability should contact ADOT's Contracts and Specifications Office by phone (602) 712-7221. Requests should be made as early as possible to ensure the State has an opportunity to address the accommodation.

Las personas que requieran asistencia (dentro de lo razonable) ya sea por el idioma o discapacidad deben ponerse en contacto con ADOT (602) 712-7221.

The bidder shall provide an electronic proposal guaranty payable to the Arizona Department of Transportation for 10 percent of the amount of the bid.

Prior to the bid opening date, any questions pertaining to the project documents shall be submitted to the Department in a written format through the Bid Express (Bidx) website at <https://www.bidx.com/az/lettings>. Questions shall be submitted through the Questions and Answers (Q&A) link located within the corresponding letting date and project proposal number links. The Department may not answer all questions, and any decision on whether a question is answered will be within the sole discretion of the Department. Any questions received less than three working days prior to the bid opening date may not be answered.

The Engineering Specialist assigned to this project is: Thomas Mowery-Racz, tmowery-racz@azdot.gov, any correspondence with the Engineering Specialist is subject to posting onto Bidx through the project's Q&A link. Answers to questions will not be given verbally, but will be posted exclusively to the Bidx website.

Brahama Singh, PE,
Group Manager,
Contracts & Specifications

Project Advertised on: March 25, 2026



ARIZONA DEPARTMENT OF TRANSPORTATION
 PROJECT DELIVERY AND OPERATIONS DIVISION
 CONTRACTS AND SPECIFICATIONS SECTION

BID RESULTS

Completion Date:

180 Working Days

The proposed project is located in Yavapai County Northwest of Wickenburg on US93, from milepost 175.5 to milepost 177.0. The work consists of widening the roadway, constructing stone matrix asphalt (SMA), roadway excavation, reinforced concrete culvert extension, guardrail, striping, rumble strips, and other related work.

Bid Opening Date : 5/1/2026, Prequalification Required, Engineer Specialist : Jalal Kamal

Project No.	Highway Termini	Location	Item
093 YV 175 F063601C 093-B-(224)T	WICKENBURG-KINGMAN HWY (US 93)	MP 175.5 to MP 177 NorthWest District	103638

Rank	Bid Amount	Contractor Name	Address of Contractor
	\$4,811,757.90	DEPARTMENT	
1	\$5,729,500.00	FANN CONTRACTING, INC	PO BOX 4356 PRESCOTT, AZ 86302-
2	\$6,178,609.90	FNF CONSTRUCTION, INC.	115 S. 48TH STREET TEMPE, AZ 85281-8504
3	\$6,714,916.30	SHOW LOW CONSTRUCTION, INC.	1801 W. DEUCE OF CLUBS, SUITE 300 SHOW LOW, AZ 85901-

Apparent Low Bidder is 19.1% Over Department Estimate (Difference = \$917,742.10)

ARIZONA DEPARTMENT OF TRANSPORTATION

ADVERTISEMENT FOR BIDS

BID OPENING: FRIDAY, MAY 01, 2026, AT 11:00 A.M. (M.S.T.)

TRACS NO 093 YV 175 F0636 01C
PROJECT NO 093-B-(224)T
TERMINI WICKENBURG – KINGMAN HIGHWAY (US93)
LOCATION MP 175.5-177 NB & MP 176.0-176.5 SB, S. of Date Creek

ROUTE NO.	MILEPOST	DISTRICT	ITEM NO.
US 93	175.5 to 177.0	NORTHWEST	103638

The amount programmed for this contract is \$6,536,486. The location and description of the proposed work are as follows:

The proposed project is located in Yavapai County Northwest of Wickenburg on US93, from milepost 175.5 to milepost 177.0. The work consists of widening the roadway, constructing stone matrix asphalt (SMA), roadway excavation, reinforced concrete culvert extension, guardrail, striping, rumble strips, and other related work.

The time allowed for the completion of the work included in this contract will be 180 working days.

The Arizona Department of Transportation, in accordance with the provisions of Title VI of the Civil Rights Act of 1964 (78 Stat. 252, 42 U.S.C. §§ 2000d to §§ 2000d-4) and the Regulations, hereby notifies all bidders that it will affirmatively ensure that any contract entered into pursuant to this advertisement, Disadvantaged Business Enterprises will be afforded full and fair opportunity to submit bids in response to this invitation and will not be discriminated against on the grounds of race, color, or national origin in consideration for an award.

Contract documents, and other project documents, if applicable, are available as electronic files, at no charge, from the Department's website through the ADOT Contracts and Specifications Group (<https://azdot.gov/business/contracts-and-specifications/current-advertisements>).

Documents will be available within one week following the advertisement for bids.

To submit a valid bid, the bidder must (1) have prequalification from the Department as necessary for the project, and (2) be included on the project Plansholder List as a Prime.

The Application for Contractor Prequalification may be obtained from the Contracts and Specifications website.

This project requires electronic bidding. If a request for approval to bid as a Prime Contractor is received less than five working days prior to bid opening, the Department cannot guarantee the request will be acted on.

This contract is subject to the provisions of Arizona Revised Statutes Section 42-5075 -- Prime contracting classification; exemptions; definitions.

No award will be made to any contractor who is not a duly licensed contractor in accordance with Arizona Revised Statutes 32-1101 through 32-1170.03.

All labor employed on this project shall be paid in accordance with the minimum wage rates shown in the General Wage Decision. These rates have been determined in accordance with the requirements of the law and issued by the Secretary of Labor for this project. The wage scale is on file in Contracts and Specifications Section and copies may be obtained at all reasonable times.

Persons that require a reasonable accommodation based on language or disability should contact ADOT's Contracts and Specifications Office by phone (602) 712-7221. Requests should be made as early as possible to ensure the State has an opportunity to address the accommodation.

Las personas que requieran asistencia (dentro de lo razonable) ya sea por el idioma o discapacidad deben ponerse en contacto con ADOT (602) 712-7221.

The bidder shall provide an electronic proposal guaranty payable to the Arizona Department of Transportation for 10 percent of the amount of the bid.

Prior to the bid opening date, any questions pertaining to the project documents shall be submitted to the Department in a written format through the Bid Express (Bidx) website at <https://www.bidx.com/az/lettings>. Questions shall be submitted through the Questions and Answers (Q&A) link located within the corresponding letting date and project proposal number links. The Department may not answer all questions, and any decision on whether a question is answered will be within the sole discretion of the Department. Any questions received less than three working days prior to the bid opening date may not be answered.

The Engineering Specialist assigned to this project is: Jalal Kamal, Jkamal@azdot.gov, any correspondence with the Engineering Specialist is subject to posting onto Bidx through the project's Q&A link. Answers to questions will not be given verbally, but will be posted exclusively to the Bidx website.

Brahama Singh, PE,
Group Manager,
Contracts & Specifications

Project Advertised on: APRIL 06, 2026



ARIZONA DEPARTMENT OF TRANSPORTATION
 PROJECT DELIVERY AND OPERATIONS DIVISION
 CONTRACTS AND SPECIFICATIONS SECTION

BID RESULTS

Completion Date:

165 Calendar Days

The proposed project is located in Yuma County within the City of Somerton at the intersection of County 15th Street and Avenue D. The work consists of installation of new advance warning flashers and LED stop signs. The work also includes grading, installing a new driveway, signing and pavement markings, and other related works.

Bid Opening Date : 5/1/2026, Prequalification Required, Engineer Specialist : Vian Rashid

Project No.	Highway Termini	Location	Item
0000 YU SOM T051701C SOM-0-(208)T	CITY OF SOMERTON	County 15th St and Ave D SouthWest District	LOCAL

Rank	Bid Amount	Contractor Name	Address of Contractor
1	\$356,467.35	AJP ELECTRIC, INC.	1920 W. CHERYL DRIVE PHOENIX, AZ 85021-
2	\$444,444.00	HAWK CONTRACTING LLC	1022 E. LOYOLA DRIVE TEMPE, AZ 85282-
	\$519,434.00	DEPARTMENT	
3	\$520,000.00	DPE CONSTRUCTION, INC.	1636 E 20TH STREET YUMA, AZ 85365-

Apparent Low Bidder is 31.4% Under Department Estimate (Difference = (\$162,966.65))

ARIZONA DEPARTMENT OF TRANSPORTATION

ADVERTISEMENT FOR BIDS

BID OPENING: FRIDAY, MAY 01, 2026, AT 11:00 A.M. (M.S.T.)

TRACS NO 0000 YU SOM T0517 01C
PROJECT NO SOM-0(208)T
TERMINI CITY OF SOMERTON
LOCATION COUNTY 15TH ST & AVE D

ROUTE NO.	MILEPOST	DISTRICT	ITEM NO.
N/A	N/A	SOUTHWEST	LOCAL

The amount programmed for this contract is \$710,000. The location and description of the proposed work are as follows:

The proposed project is located in Yuma County within the City of Somerton at the intersection of County 15th Street and Avenue D. The work consists of installation of new advance warning flashers and LED stop signs. The work also includes grading, installing a new driveway, signing and pavement markings, and other related works.

The time allowed for the completion of the work included in this contract will be 165 calendar days.

The Arizona Department of Transportation, in accordance with the provisions of Title VI of the Civil Rights Act of 1964 (78 Stat. 252, 42 U.S.C. §§ 2000d to §§ 2000d-4) and the Regulations, hereby notifies all bidders that it will affirmatively ensure that any contract entered into pursuant to this advertisement, Disadvantaged Business Enterprises will be afforded full and fair opportunity to submit bids in response to this invitation and will not be discriminated against on the grounds of race, color, or national origin in consideration for an award.

Contract documents, and other project documents, if applicable, are available as electronic files, at no charge, from the Department's website through the ADOT Contracts and Specifications Group (<https://azdot.gov/business/contracts-and-specifications/current-advertisements>).

Documents will be available within one week following the advertisement for bids.

To submit a valid bid, the bidder must (1) have prequalification from the Department as necessary for the project, and (2) be included on the project Plansholder List as a Prime.

The Application for Contractor Prequalification may be obtained from the Contracts and Specifications website.

This project requires electronic bidding. If a request for approval to bid as a Prime Contractor is received less than five working days prior to bid opening, the Department cannot guarantee the request will be acted on.

This contract is subject to the provisions of Arizona Revised Statutes Section 42-5075 -- Prime contracting classification; exemptions; definitions.

No award will be made to any contractor who is not a duly licensed contractor in accordance with Arizona Revised Statutes 32-1101 through 32-1170.03.

All labor employed on this project shall be paid in accordance with the minimum wage rates shown in the General Wage Decision. These rates have been determined in accordance with the requirements of the law and issued by the Secretary of Labor for this project. The wage scale is on file in Contracts and Specifications Section and copies may be obtained at all reasonable times.

Persons that require a reasonable accommodation based on language or disability should contact ADOT's Contracts and Specifications Office by phone (602) 712-7221. Requests should be made as early as possible to ensure the State has an opportunity to address the accommodation.

Las personas que requieran asistencia (dentro de lo razonable) ya sea por el idioma o discapacidad deben ponerse en contacto con ADOT (602) 712-7221.

The bidder shall provide an electronic proposal guaranty payable to the Arizona Department of Transportation for 10 percent of the amount of the bid.

Prior to the bid opening date, any questions pertaining to the project documents shall be submitted to the Department in a written format through the Bid Express (Bidx) website at <https://www.bidx.com/az/lettings>. Questions shall be submitted through the Questions and Answers (Q&A) link located within the corresponding letting date and project proposal number links. The Department may not answer all questions, and any decision on whether a question is answered will be within the sole discretion of the Department. Any questions received less than three working days prior to the bid opening date may not be answered.

The Engineering Specialist assigned to this project is: Vian rashid, vrashid@azdot.gov, any correspondence with the Engineering Specialist is subject to posting onto Bidx through the project's Q&A link. Answers to questions will not be given verbally, but exclusively to the Bidx website.

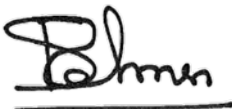

For Brahma Singh, PE,
Group Manager,
Contracts & Specifications

Project Advertised on: 03/30/2026



206 S. 17th Ave.
MD 139A
Phoenix, AZ 85007

KATIE HOBBS
GOVERNOR

JENNIFER TOTH
DIRECTOR

GMP1 Recommendation Memorandum

TO: Robert Samour, Division Director

FROM: Myrna Bondoc, Project Manager

CC: Brahma Singh – Contracts and Specifications Group Manager
 Sarker Rahman – Contract and Specifications
 Paul Patane – District Engineer
 Jon Fell – Assistant District Engineer
 Isabell Garcia – Project Development

DATE: **May 26, 2026**

Project No.: **010 MA 086 F077901C**

Federal ID No.: **010-A(242)T**

Location: **BURNT WELL REST AREA**

In accordance with the Arizona Department of Transportation (ADOT) Construction Manager at Risk (CMAR) Process Guide, this memorandum provides ADOT Alternative Deliveries and Major Projects recommendation on the final price proposal submitted for the above referenced project.

ADOT received the Guaranteed Maximum Price 1 (GMP1) dated May 20, 2026 from Rummel Construction the CMAR selected for preconstruction services. The GMP1 package including the GMP tables are attached for your review and concurrence.

ADOT Alternative Delivery and Major Projects hereby recommend that this final cost proposal be accepted as the Guaranteed Maximum Price 1 (GMP1) of \$1,270,473.82.

<p>DocuSigned by: <i>Myrna Bondoc</i> <small>231EE09349D1455...</small></p>	<p>5/26/2026</p>
<p>Myrna Bondoc Project Manager</p>	<p>Date</p>

State Engineer’s Office Concurrence with recommendation:

<p>Signed by: <i>Robert Samour</i> <small>AG59D974B69D46E...</small></p>	<p>5/26/2026</p>
<p>Robert Samour, PE ADMP Division Director</p>	<p>Date</p>



Alternative Delivery and Major Projects Division

Burnt Well Rest Area Truck Parking Expansion Project

010 MA 086 F0779 01D

Final List

Proposer	Rank
Rummel Construction, Inc.	1
FNF Construction, Inc.	2